



**Installation Instruction**  
**Manual for washers**  
**HS-6013/HS-6017/HS-6023/**  
**HS-6024/HS-6028/HS-6032**  
**EH030/EH040/EH055/**  
**EH060/EH070/EH080**

**GIRBAU, SA**

Crta de Manlleu, km. 1  
08500 VIC (Barcelona) • SPAIN

**National sales:**

T. (+ 34) 902 300 359

[comercial@girbau.es](mailto:comercial@girbau.es)

**International sales:**

T. (+ 34) 938 862 219

[sales@girbau.es](mailto:sales@girbau.es)

**Service:**

T. (+ 34) 902 300 357

[sat@girbau.es](mailto:sat@girbau.es)

[www.girbau.es](http://www.girbau.es)

**For USA and CANADA:**

**CONTINENTAL GIRBAU Inc.**

2500 State Road 44

WI 54904 Oshkosh • USA

Tel. 1(920) 231-8222

[info@continentalgirbau.com](mailto:info@continentalgirbau.com)

[www.continentalgirbau.com](http://www.continentalgirbau.com)



**EN**  
**Installation**

<b>Model</b>	<b>From serial #</b>
<b>HS-6013</b>	2,110,001
<b>EH030</b>	1,460,001
<b>HS-6017</b>	2,120,001
<b>EH040</b>	1,470,001
<b>HS-6023</b>	2,140,001
<b>EH055</b>	1,490,001
<b>HS-6024</b>	2,390,177
<b>EH060</b>	2,400,387
<b>HS-6028</b>	2,520,000
<b>EH070</b>	2,520,000
<b>HS-6032</b>	2,450,001
<b>EH080</b>	2,460,001

<b>CONTENTS</b> .....	<b>2</b>
<b>SAFETY INSTRUCTIONS</b> .....	<b>3</b>
<b>1. TECHNICAL SPECIFICATIONS</b> .....	<b>7</b>
1.1. Tools needed for installation .....	7
1.2. Accessories in machine.....	7
1.3. Declaration of conformity.....	8
1.4. Installation specifications.....	15
1.5. Connection table explanation .....	19
1.6. Electrical requirements.....	20
<b>2. RECEIPT, TRANSPORT AND LOCATION</b> .....	<b>28</b>
2.1. Receipt .....	28
2.2. Transport of the machine .....	28
2.3. Safety door unlock (HS-6023, HS-6024, HS-6028, HS-6032, EH055, EH060, EH070, EH080 models only).....	29
2.4. Washer location Conditions.....	29
2.5. Installing more than one washer .....	31
2.6. Removal of shipping braces.....	32
2.6.1. HS-6013, HS-6017, HS-6024, HS-6028, HS-6032, EH030, EH040, EH060, EH070, EH080 models.....	32
2.6.2. HS-6023, EH055 models .....	33
<b>3. INSTALLATION</b> .....	<b>34</b>
3.1. Drain .....	34
3.2. Water supply.....	36
3.3. Electrical connection .....	38
3.3.1. Previous requirements .....	38
3.3.2. Installation characteristics.....	38
3.3.3. Machine electrical connection.....	39
3.3.4. Transformer connection. Configuring the machine voltage .....	40
3.4. Steam connection.....	42
3.5. External dosing (option) .....	42
3.5.1. External dosing electrical connection .....	43
3.5.2. External dosing hoses connection .....	45
3.5.3. Busy dosing unit signal .....	45
3.6. External signal. Connection.....	46
3.7. Tensioning belts .....	46
3.8. Initial start-up.....	47
3.9. Emergency stop in coin-op installations.....	47
3.10. Wash cycle start-up from an external device to the washing machine .....	47
3.10.1. Connecting to a central vending unit and configuring the machine.....	47

 **WARNING!****TRANSPORT, INSTALLATION, INSPECTION, MAINTENANCE, REPAIR OR MODIFICATION ROUTINES ON GIRBAU EQUIPMENT**

1. The actions described in these instructions are strictly reserved for contractually **AUTHORISED TECHNICAL SERVICES (ATS)** and personnel who have successfully completed training by Girbau SA.
2. The company responsible for the Authorised Technical Service accepts full liability for the work done and any possible consequences that may derive from it.
3. Any actions carried out by personnel who are not authorised by the manufacturer will be considered to be improper and will result in the automatic voiding of the machine's warranty.
4. The manufacturer will not accept responsibility for any physical and/or material damage caused by actions performed on the machine undertaken by unauthorised personnel.
5. Do not store or install the machine in areas exposed to the ELEMENTS or where it may be splashed by water.
6. The room where the machine is located **MUST** comply with the environmental conditions (air venting, temperature, humidity, etc.) specified in the technical specifications table. **NEVER INSTALL THE MACHINE IN ENVIRONMENTS** where it will be splashed with water or where there is a very high level of humidity in the atmosphere.
7. All installations required for the proper operation of the machine **MUST** be carried out by a duly accredited Registered Installation Contractors, in compliance with the legal regulations applicable in the country of use.
8. Once the corresponding operation has been performed, the ATS staff must perform the final machine inspection.
9. Avoid carrying out any action on the machine without having first read and understood the machine's Installation and Operating Manuals, paying special attention to the Safety Instructions.
10. In any action that modifies the values of the machine's specifications plate, it should be borne in mind that:
  - It is the responsibility of the ATS to check that the external installation for the machine has been modified and adapted to the new requirements, particularly to those regarding ducting and electrical protection.
  - It is the responsibility of the ATS to update the specifications plate, in accordance with the new operation conditions, once the final machine inspection has been performed.
11. Carrying out transport, installation, inspection routines, adjustments, maintenance, repairs, cleaning or any work on the machines without applying safety measures or having the necessary technical know-how can lead to **ELECTRICAL SHOCK OR SERIOUS ACCIDENTS**.
12. When tools designed for specific transport, installation, maintenance and repair routines are available, their use is compulsory in order to avoid unnecessary risks.
13. Before carrying out any procedures on machines fitted with pneumatic or hydraulic circuits:
  - Make the machines **COMPLETELY SAFE** by following the instructions set out in the corresponding Manuals or by wedging them with wooden blocks where necessary.
  - Bear in mind that working on a component without having previously understood the role that it performs in the circuit as a whole involves a high risk of suffering a **SERIOUS ACCIDENT**.
14. **BEFORE CARRYING OUT ANY** inspection routine, adjustment, maintenance, repairs, cleaning or any work on the machine, **DISCONNECT IT FROM ALL THE ENERGY SOURCES**.
  - **COMPLETELY** disconnect the machine from the power supply and prevent the possibility of accidental reconnection by mechanically locking the automatic external switch and/or the switch breaker. Stopping the machine with the **NORMAL STOP** key or push-button is not enough.
  - Disconnect the electrical connection of any circuit external to the machine; for example external dosing equipment, external vending units, folders or ironer feeders. These circuits are independent of the supply to the machine.

- Before beginning any procedure on machines equipped with an inverter or equipment with capacitive loads, wait for at least five minutes (10 minutes on equipment with a power rating greater than 25 kW) after the electrical disconnection, to eliminate risk of residual voltage.
  - Close and mechanically lock the manual WATER, GAS, STEAM, THERMAL OIL, COMPRESSED AIR, etc. supply valves.
  - Check that the water bath has **COMPLETELY** drained, that no part of the machine is at an excessively high temperature and that no parts are in movement through inertia.
15. **DANGER!** Some fault localisation procedures require checking at different points of the electric circuit with the machine connected to the power supply and other supply sources. When carrying out these procedures, respect the following instructions:
- The appropriate checks must be carried out by **ONLY ONE PERSON**.
  - During these procedures, **ONLY** remove the protective covers from the electric circuit and/or the inverter. Never remove the covers protecting the moving parts of the machine.
16. **THE MANUFACTURER ACCEPTS NO RESPONSIBILITY IF THESE SAFETY INSTRUCTIONS AND ALL THE INFORMATION IN THE CORRESPONDING MANUALS ARE NOT FOLLOWED. KEEP THESE INSTRUCTIONS IN A SAFE PLACE.**

**SYMBOLS USED IN MACHINE LABELLING**

	<p><b>Electrical risk</b> Protective guard for elements carrying an electric current.</p>		<p><b>High temperature risk</b> Handle with caution. Use adequate protection.</p>
	<p><b>Mechanical risk</b> Protective guard for moving parts.</p>		<p><b>Risk of inhaling harmful or irritant vapours</b> Keep the doors/covers closed. Use adequate protection.</p>
	<p><b>Flame risk (only on some machines)</b> Protective guard for flame.</p>		<p><b>Risk of falling</b> Use proper access and safety methods.</p>
	<p><b>Access prohibited</b></p>		<p><b>See Instructions manual</b></p>

**SYMBOLS USED IN THIS MANUAL**

	<p>Symbol used to highlight a possible HAZARD, WARNING or NOTE.</p>		<p>This symbol is used to emphasise a particular explanation.</p>
--	---	--	---

**TRANSLATION OF THE ORIGINAL MANUAL**

## 1. TECHNICAL SPECIFICATIONS

### 1.1. Tools needed for installation

#### HS-6013; HS-6017; EH030; EH040

- Shipping restraints ..... open end wrench 11/16 inch. (17mm)
- Shipping restraints ..... tubular wrench 11/16 inch. (17mm)

#### HS-6023; HS-6024; HS-6028; HS-6032; EH055; EH060; EH070; EH080

- Shipping restraints ..... open end wrench ¾ inch. (19mm)
- Shipping restraints ..... offset ring wrench ¾ inch. (19 mm)
- Shipping restraints ..... tubular wrench ¾ in. (19 mm)

#### Common to all models

- Clamps ..... nut driver 7mm
- Water inlet filters ..... open end wrench 1 3/8 inch. (34mm)
- Covers fixing ..... open end wrench 1/2 inch. (13mm)
- Water inlet hoses ..... slip-joint pliers or pipe wrench diam. 1 1/2 in (35 mm )
- Covers fixing ..... TORX T25 screwdriver
- Covers fixing ..... TORX T20 screwdriver.
- Electrical requirements ..... Phillips 2 screwdriver (#2).
- External dosing connection ..... slotted-head screwdriver 3mm.
- Vending circuit connection ..... slotted-head screwdriver 3mm & Philips 1 (#1)

### 1.2. Accessories in machine

Keep all machine instructions in a safe place.

ACCESSORIES	QUANTITY	NOTES
Drain hose .....	1	(1) not available USA / Canada
Drain clamp .....	1	(2) machines with third water inlet: 2 units
Cold water inlet hose (1) .....	1	(3) machines with third water inlet: 3 units
Hot water inlet hose (1) .....	1 (2)	(4) machines no USA/Canada with third water inlet: 9 units
Water inlet couplings .....	2 (3)	(5) machines USA/Canada 2 units, with third water inlet: 3 units
Water inlet filter .....	2 (3)	(6) steam heating machines
Water inlet hoses gaskets .....	6 (4) (5)	(7) only machines in USA / Canada with steam heating
Steam inlet filter and valve (6).....	1	(8) Coin control models only
Water inlet coupling (7) .....	1	(9) depending on model and voltage
Top cover key .....	1	(10) depending on target country
Coin meter box key (8) (10).....	1	
Coin meter tokens (8) (10) .....	10	
Fuses .....	(9)	
Installation handbook .....	1	
Operation handbook.....	1	
Parts handbook (1).....	1	
Documentation .....	(10)	

## 1.3. Declaration of conformity

**HS-6013 model**

### EU DECLARATION OF CONFORMITY

Manufacturer: GIRBAU S.A.

Address: Ctra. de Manlleu, km 1, 08500 Vic, Barcelona, SPAIN

Identification of the machine

Generic denomination:	Function:	Type:
Washer extractor Lavadora – centrifugadora Wasch – und Schleudermaschine Laveuse –essoreuse Lavatrice – centrifugatrice Rentadora – centrifugadora Máquina de lavar – centrifugar 洗衣机 – 脱水机	Washing in a water bath and extracting textiles Lavar en baño de agua y centrifugar géneros textiles Das Waschen im Waschbad und das Ausschleudern von Textilien Laver en bain d'eau et essorer textiles Lavare in bagno d'acqua e centrifugare tessuti Rentar en bany d'aigua i centrifugar teixits Lavagem com banho de água e centrifugação de géneros têxteis 纺织物的湿洗和脱水	Front loading Carga frontal Frontladung Chargement frontal Carico frontale Càrrega frontal Carga frontal 前装式

Model: **HS-6013**

The manufacturer declares under its sole responsibility that the specified equipment has been manufactured in compliance with:

El fabricante declara bajo su exclusiva responsabilidad que el producto especificado se ha fabricado conforme a:

Der Hersteller bestätigt, dass das vorstehend bezeichnete Produkt gemäß den folgenden Richtlinien:

Le fabricant déclare, sous sa seule responsabilité, que le produit spécifié a été fabriqué conformément à:

Il fabbricante dichiara, sotto la sua esclusiva responsabilità, che il prodotto specificato é fabbricato secondo:

El fabricant declara, sota la seva exclusiva responsabilitat, que el producte especificat s'ha fabricat conforme a:

O fabricante declara sob a sua inteira responsabilidade que o produto referido é fabricado em conformidade com:

制造商全权声明 · 指定产品的制造符合以下要求:

2006/42/EC Machine Safety Directive

Main harmonized standards: EN ISO 10472-1:2008, EN ISO 10472-2:2008, EN 12100:2010, EN 13849-1:2015

2014/35/EU Low Voltage Directive

Main harmonized standards: EN 60204-1:2010

2014/30/EU Electromagnetic Compatibility Directive

Main harmonized standards: EN 61000-3-11:2000, EN 61000-6-3:2007, EN 61000-3-12:2011, EN 61000-6-2:2005

2011/65/EU Hazardous Substances in Electrical and Electronic Equipment Directive

Main harmonized standards: EN 50581:2012

2012/19/EU Waste Electrical and Electronic Equipment Directive (not a CE Marking Directive)



## HS-6017 model

### EU DECLARATION OF CONFORMITY

Manufacturer: GIRBAU S.A.

Address: Ctra. de Manlleu, km 1, 08500 Vic, Barcelona, SPAIN

Identification of the machine

Generic denomination:	Function:	Type:
Washer extractor Lavadora – centrifugadora Wasch – und Schleudermaschine Laveuse –essoreuse Lavatrice – centrifugatrice Rentadora – centrifugadora Máquina de lavar – centrifugar 洗衣机 – 脱水机	Washing in a water bath and extracting textiles Lavar en baño de agua y centrifugar géneros textiles Das Waschen im Waschbad und das Ausschleudern von Textilien Laver en bain d'eau et essorer textiles Lavare in bagno d'acqua e centrifugare tessuti Rentar en bany d'aigua i centrifugar teixits Lavagem com banho de água e centrifugação de géneros têxteis 纺织物的湿洗和脱水	Front loading Carga frontal Frontladung Chargement frontal Carico frontale Càrrega frontal Carga frontal 前装式

### Model: **HS-6017**

The manufacturer declares under its sole responsibility that the specified equipment has been manufactured in compliance with:

El fabricante declara bajo su exclusiva responsabilidad que el producto especificado se ha fabricado conforme a:

Der Hersteller bestätigt, dass das vorstehend bezeichnete Produkt gemäß den folgenden Richtlinien:

Le fabricant déclare, sous sa seule responsabilité, que le produit spécifié a été fabriqué conformément à:

Il fabbricante dichiara, sotto la sua esclusiva responsabilità, che il prodotto specificato è fabbricato secondo:

El fabricant declara, sota la seva exclusiva responsabilitat, que el producte especificat s'ha fabricat conforme a:

O fabricante declara sob a sua inteira responsabilidade que o produto referido é fabricado em conformidade com:

制造商全权声明 · 指定产品的制造符合以下要求:

#### 2006/42/EC Machine Safety Directive

Main harmonized standards: EN ISO 10472-1:2008, EN ISO 10472-2:2008, EN 12100:2010, EN 13849-1:2015

#### 2014/35/EU Low Voltage Directive

Main harmonized standards: EN 60204-1:2010

#### 2014/30/EU Electromagnetic Compatibility Directive

Main harmonized standards: EN 61000-3-11:2000, EN 61000-6-3:2007, EN 61000-3-12:2011, EN 61000-6-2:2005

#### 2011/65/EU Hazardous Substances in Electrical and Electronic Equipment Directive

Main harmonized standards: EN 50581:2012

#### 2012/19/EU Waste Electrical and Electronic Equipment Directive (not a CE Marking Directive)

## HS-6023 – 1Ph model

### EU DECLARATION OF CONFORMITY

Manufacturer: GIRBAU S.A.

Address: Ctra. de Manlleu, km 1, 08500 Vic, Barcelona, SPAIN

Identification of the machine

Generic denomination:	Function:	Type:
Washer extractor Lavadora – centrifugadora Wasch – und Schleudermaschine Laveuse –essoreuse Lavatrice – centrifugatrice Rentadora – centrifugadora Máquina de lavar – centrifugar 洗衣机 – 脱水机	Washing in a water bath and extracting textiles Lavar en baño de agua y centrifugar géneros textiles Das Waschen im Waschbad und das Ausschleudern von Textilien Laver en bain d'eau et essorer textiles Lavare in bagno d'acqua e centrifugare tessuti Rentar en bany d'aigua i centrifugar teixits Lavagem com banho de água e centrifugação de géneros têxteis 纺织物的湿洗和脱水	Front loading Carga frontal Frontladung Chargement frontal Carico frontale Càrrega frontal Carga frontal 前装式

### Model: **HS-6023 1PH**

The manufacturer declares under its sole responsibility that the specified equipment has been manufactured in compliance with:

El fabricante declara bajo su exclusiva responsabilidad que el producto especificado se ha fabricado conforme a:

Der Hersteller bestätigt, dass das vorstehend bezeichnete Produkt gemäß den folgenden Richtlinien:

Le fabricant déclare, sous sa seule responsabilité, que le produit spécifié a été fabriqué conformément à:

Il fabbricante dichiara, sotto la sua esclusiva responsabilità, che il prodotto specificato è fabbricato secondo:

El fabricant declara, sota la seva exclusiva responsabilitat, que el producte especificat s'ha fabricat conforme a:

O fabricante declara sob a sua inteira responsabilidade que o produto referido é fabricado em conformidade com:

制造商全权声明 · 指定产品的制造符合以下要求:

#### 2006/42/EC Machine Safety Directive

Main harmonized standards: EN ISO 10472-1:2008, EN ISO 10472-2:2008, EN 12100:2010, EN 13849-1:2015

#### 2014/35/EU Low Voltage Directive

Main harmonized standards: EN 60204-1:2010

#### 2014/30/EU Electromagnetic Compatibility Directive

Main harmonized standards: EN 61000-3-12:2011, EN 61000-6-3:2007, EN 61000-3-3:2013, EN 61000-6-1:2007

#### 2011/65/EU Hazardous Substances in Electrical and Electronic Equipment Directive

Main harmonized standards: EN 50581:2012

#### 2012/19/EU Waste Electrical and Electronic Equipment Directive (not a CE Marking Directive)

## HS-6023 – 3Ph model

### EU DECLARATION OF CONFORMITY

Manufacturer: GIRBAU S.A.

Address: Ctra. de Manlleu, km 1, 08500 Vic, Barcelona, SPAIN

Identification of the machine

Generic denomination:	Function:	Type:
Washer extractor Lavadora – centrifugadora Wasch – und Schleudermaschine Laveuse – essoreuse Lavatrice – centrifugatrice Rentadora – centrifugadora Máquina de lavar – centrifugar 洗衣机 – 脱水机	Washing in a water bath and extracting textiles Lavar en baño de agua y centrifugar géneros textiles Das Waschen im Waschbad und das Ausschleudern von Textilien Laver en bain d'eau et essorer textiles Lavare in bagno d'acqua e centrifugare tessuti Rentar en bany d'aigua i centrifugar teixits Lavagem com banho de água e centrifugação de géneros têxteis 纺织物的湿洗和脱水	Front loading Carga frontal Frontladung Chargement frontal Carico frontale Càrrega frontal Carga frontal 前装式

### Model: HS-6023 3PH

The manufacturer declares under its sole responsibility that the specified equipment has been manufactured in compliance with:

El fabricante declara bajo su exclusiva responsabilidad que el producto especificado se ha fabricado conforme a:

Der Hersteller bestätigt, dass das vorstehend bezeichnete Produkt gemäß den folgenden Richtlinien:

Le fabricant déclare, sous sa seule responsabilité, que le produit spécifié a été fabriqué conformément à:

Il fabbricante dichiara, sotto la sua esclusiva responsabilità, che il prodotto specificato è fabbricato secondo:

El fabricant declara, sota la seva exclusiva responsabilitat, que el producte especificat s'ha fabricat conforme a:

O fabricante declara sob a sua inteira responsabilidade que o produto referido é fabricado em conformidade com:

制造商全权声明 · 指定产品的制造符合以下要求:

#### 2006/42/EC Machine Safety Directive

Main harmonized standards: EN ISO 10472-1:2008, EN ISO 10472-2:2008, EN 12100:2010, EN 13849-1:2015

#### 2014/35/EU Low Voltage Directive

Main harmonized standards: EN 60204-1:2010

#### 2014/30/EU Electromagnetic Compatibility Directive

Main harmonized standards: EN 61000-3-12:2011, EN 61000-6-3:2007, EN 61000-3-3:2013, EN 61000-6-1:2007

#### 2011/65/EU Hazardous Substances in Electrical and Electronic Equipment Directive

Main harmonized standards: EN 50581:2012

#### 2012/19/EU Waste Electrical and Electronic Equipment Directive (not a CE Marking Directive)



#### CAUTION

#### **Compliance with Directive of Electromagnetic Compatibility.**

**Professional equipment.** This equipment is for professional, commercial and industrial use and it is not to be sold for domestic use.

The connection of this equipment to a public low voltage power supply is conditional to the power supply connection requirements established by the distribution power supplier.

## HS-6024 model

### EU DECLARATION OF CONFORMITY

Manufacturer: GIRBAU S.A.

Address: Ctra. de Manlleu, km 1, 08500 Vic, Barcelona, SPAIN

Identification of the machine

Generic denomination:	Function:	Type:
Washer extractor Lavadora – centrifugadora Wasch – und Schleudermaschine Laveuse –essoreuse Lavatrice – centrifugatrice Rentadora – centrifugadora Máquina de lavar – centrifugar 洗衣机 – 脱水机	Washing in a water bath and extracting textiles Lavar en baño de agua y centrifugar géneros textiles Das Waschen im Waschbad und das Ausschleudern von Textilien Laver en bain d'eau et essorer textiles Lavare in bagno d'acqua e centrifugare tessuti Rentar en bany d'aigua i centrifugar teixits Lavagem com banho de água e centrifugação de géneros têxteis 纺织物的湿洗和脱水	Front loading Carga frontal Frontladung Chargement frontal Carico frontale Càrrega frontal Carga frontal 前装式

### Model: **HS-6024**

The manufacturer declares under its sole responsibility that the specified equipment has been manufactured in compliance with:

El fabricante declara bajo su exclusiva responsabilidad que el producto especificado se ha fabricado conforme a:

Der Hersteller bestätigt, dass das vorstehend bezeichnete Produkt gemäß den folgenden Richtlinien:

Le fabricant déclare, sous sa seule responsabilité, que le produit spécifié a été fabriqué conformément à:

Il fabbricante dichiara, sotto la sua esclusiva responsabilità, che il prodotto specificato è fabbricato secondo:

El fabricant declara, sota la seva exclusiva responsabilitat, que el producte especificat s'ha fabricat conforme a:

O fabricante declara sob a sua inteira responsabilidade que o produto referido é fabricado em conformidade com:

制造商全权声明 · 指定产品的制造符合以下要求:

#### 2006/42/EC Machine Safety Directive

Main harmonized standards: EN ISO 10472-1:2008, EN ISO 10472-2:2008, EN 12100:2010, EN 13849-1:2015

#### 2014/35/EU Low Voltage Directive

Main harmonized standards: EN 60204-1:2010

#### 2014/30/EU Electromagnetic Compatibility Directive

Main harmonized standards: EN 61000-6-2:2005, EN 61000-6-3:2007, EN 61000-3-2:2014, EN 61000-3-3:2013

#### 2011/65/EU Hazardous Substances in Electrical and Electronic Equipment Directive

Main harmonized standards: EN 50581:2012

#### 2012/19/EU Waste Electrical and Electronic Equipment Directive (not a CE Marking Directive)

## HS-6028 model

### EU DECLARATION OF CONFORMITY

Manufacturer: GIRBAU S.A.

Address: Ctra. de Manlleu, km 1, 08500 Vic, Barcelona, SPAIN

Identification of the machine

Generic denomination:	Function:	Type:
Washer extractor Lavadora – centrifugadora Wasch – und Schleudermaschine Laveuse –essoreuse Lavatrice – centrifugatrice Rentadora – centrifugadora Máquina de lavar – centrifugar 洗衣机 – 脱水机	Washing in a water bath and extracting textiles Lavar en baño de agua y centrifugar géneros textiles Das Waschen im Waschbad und das Ausschleudern von Textilien Laver en bain d'eau et essorer textiles Lavare in bagno d'acqua e centrifugare tessuti Rentar en bany d'aigua i centrifugar teixits Lavagem com banho de água e centrifugação de géneros têxteis 纺织物的湿洗和脱水	Front loading Carga frontal Frontladung Chargement frontal Carico frontale Càrrega frontal Carga frontal 前装式

### Model: **HS-6028**

The manufacturer declares under its sole responsibility that the specified equipment has been manufactured in compliance with:

El fabricante declara bajo su exclusiva responsabilidad que el producto especificado se ha fabricado conforme a:

Der Hersteller bestätigt, dass das vorstehend bezeichnete Produkt gemäß den folgenden Richtlinien:

Le fabricant déclare, sous sa seule responsabilité, que le produit spécifié a été fabriqué conformément à:

Il fabbricante dichiara, sotto la sua esclusiva responsabilità, che il prodotto specificato è fabbricato secondo:

El fabricant declara, sota la seva exclusiva responsabilitat, que el producte especificat s'ha fabricat conforme a:

O fabricante declara sob a sua inteira responsabilidade que o produto referido é fabricado em conformidade com:

制造商全权声明 · 指定产品的制造符合以下要求:

#### 2006/42/EC Machine Safety Directive

Main harmonized standards: EN ISO 10472-1:2008, EN ISO 10472-2:2008, EN 12100:2010, EN 13849-1:2015

#### 2014/35/EU Low Voltage Directive

Main harmonized standards: EN 60204-1:2010

#### 2014/30/EU Electromagnetic Compatibility Directive

#### 2011/65/EU Hazardous Substances in Electrical and Electronic Equipment Directive

Main harmonized standards: EN 50581:2012

#### 2012/19/EU Waste Electrical and Electronic Equipment Directive (not a CE Marking Directive)

## HS-6032 model

### EU DECLARATION OF CONFORMITY

Manufacturer: GIRBAU S.A.

Address: Ctra. de Manlleu, km 1, 08500 Vic, Barcelona, SPAIN

Identification of the machine

Generic denomination:	Function:	Type:
Washer extractor Lavadora – centrifugadora Wasch – und Schleudermaschine Laveuse –essoreuse Lavatrice – centrifugatrice Rentadora – centrifugadora Máquina de lavar – centrifugar 洗衣机 – 脱水机	Washing in a water bath and extracting textiles Lavar en baño de agua y centrifugar géneros textiles Das Waschen im Waschbad und das Ausschleudern von Textilien Laver en bain d'eau et essorer textiles Lavare in bagno d'acqua e centrifugare tessuti Rentar en bany d'aigua i centrifugar teixits Lavagem com banho de água e centrifugação de géneros têxteis 纺织物的湿洗和脱水	Front loading Carga frontal Frontladung Chargement frontal Carico frontale Càrrega frontal Carga frontal 前装式

### Model: **HS-6032**

The manufacturer declares under its sole responsibility that the specified equipment has been manufactured in compliance with:

El fabricante declara bajo su exclusiva responsabilidad que el producto especificado se ha fabricado conforme a:

Der Hersteller bestätigt, dass das vorstehend bezeichnete Produkt gemäß den folgenden Richtlinien:

Le fabricant déclare, sous sa seule responsabilité, que le produit spécifié a été fabriqué conformément à:

Il fabbricante dichiara, sotto la sua esclusiva responsabilità, che il prodotto specificato è fabbricato secondo:

El fabricant declara, sota la seva exclusiva responsabilitat, que el producte especificat s'ha fabricat conforme a:

O fabricante declara sob a sua inteira responsabilidade que o produto referido é fabricado em conformidade com:

制造商全权声明 · 指定产品的制造符合以下要求:

#### 2006/42/EC Machine Safety Directive

Main harmonized standards: EN ISO 10472-1:2008, EN ISO 10472-2:2008, EN 12100:2010, EN 13849-1:2015

#### 2014/35/EU Low Voltage Directive

Main harmonized standards: EN 60204-1:2010

#### 2014/30/EU Electromagnetic Compatibility Directive

Main harmonized standards: EN 61000-6-2:2005, EN 61000-6-3:2007, EN 61000-3-2:2014, EN 61000-3-3:2013

#### 2011/65/EU Hazardous Substances in Electrical and Electronic Equipment Directive

Main harmonized standards: EN 50581:2012

#### 2012/19/EU Waste Electrical and Electronic Equipment Directive (not a CE Marking Directive)

## 1.4. Installation specifications

### General specifications

	UNITS	HS-6013 EH030	HS-6017 EH040	HS-6023 EH055
DRUM VOLUME	dm <sup>3</sup> (cu. ft)	126 (4.4)	173 (6.1)	228 (8.1)
DRY LINEN CAPACITY	kg 1/10 (lbs.)	12.6 (28)	17.3 (38)	22.8 (50.3)
SPIN	r.p.m.	600 / 1005	550 / 950	330 / 920
	G factor	125 / 351	119 / 354	45 / 351
WASHING SPEED (max.)	r.p.m.	46.5	44	43
STATIC LOAD TRANSMITTED	kg (lb.)	409 (902)	561 (1237)	841 (1854)
DYNAMIC LOAD TRANSMITTED	kg (lb.)	91 (201)	96 (212)	117 (258)
FREQUENCY DYNAMIC LOAD	Hz	16.7	15.8	15.3
KINETIC ENERGY	N □ m	29720	49000	66643
MAXIMUM THERMAL SHOCK	°C (F)	90 (162)	90 (162)	90 (162)
MAXIMUM SOUND LEVEL	dbA	< 70	< 70	< 70
PROTECTION INDEX	IP	21C	21C	21C

	UNITS	HS-6024 EH060	HS-6028 EH070	HS-6032 EH080
DRUM VOLUME	dm <sup>3</sup> (cu. ft)	239 (8.4)	280 (9.9)	320 (11.3)
DRY LINEN CAPACITY	kg 1/10 (lbs.)	23.9 (52.7)	28 (61.7)	32.0 (70.5)
SPIN	r.p.m.	350 / 966	336 / 937	336 / 931
	G factor	52 / 400	52 / 405	52 / 400
WASHING SPEED (max.)	r.p.m.	42	42	42
STATIC LOAD TRANSMITTED	kg (lb.)	693 (1528)	812 (1790)	839 (1850)
DYNAMIC LOAD TRANSMITTED	kg (lb.)	132 (291)	183 (403)	187 (412)
FREQUENCY DYNAMIC LOAD	Hz	16.1	15.5	15.5
KINETIC ENERGY	N □ m	74789	82143	88347
MAXIMUM THERMAL SHOCK	°C (F)	90 (162)	90 (162)	90 (162)
MAXIMUM SOUND LEVEL	dbA	< 70	< 70	< 70
PROTECTION INDEX	IP	24	21C	21C

### Dimensions & weights

		UNITS	HS-6013 EH030	HS-6017 EH040	HS-6023 EH055
WITH CRATING	H	mm (in)	1485 (58.5)	1565 (61.6)	1650 (65.0)
	L	mm (in)	823 (32.4)	897 (35.3)	1025 (40.4)
	P	mm (in)	945 (37.2)	1017 (40)	1255 (49.4)
	WEIGHT	kg (lbs.)	372 (820)	495 (1091)	765 (1687)
WITHOUT CRATING	H	mm (in)	1325 (52.2)	1404 (55.3)	1470 (57.9)
	L	mm (in)	796 (31.3)	868 (34.2)	1000 (39.4)
	P	mm (in)	887 (34.9)	962 (37.9)	1240 (48.8)
	M	mm (in)	509 (20)	515 (20.3)	535 (21.1)
	 CdG K	mm (in)	540 (21.3)	517 (20.4)	567 (22.3)
	 CdG J	mm (in)	380 (15.0)	740 (29.1)	407 (16)
	WEIGHT	kg (lbs.)	344 (758)	476 (1049)	726 (1601)

		UNITS	HS-6024 EH060	HS-6028 EH070	HS-6032 EH080
WITH CRATING	H	mm (in)	1635 (64.4)	1657 (65.2)	1657 (65.2)
	L	mm (in)	1002 (39.4)	1075 (42.3)	1075 (42.3)
	P	mm (in)	1260 (49.6)	1320 (52.0)	1320 (52.0)
	WEIGHT	kg (lbs.)	607 (1338)	673 (1484)	718 (1583)
WITHOUT CRATING	H	mm (in)	1480 (58.3)	1500 (59.1)	1500 (59.1)
	L	mm (in)	975 (38.4)	1053 (41.5)	1053 (41.5)
	P	mm (in)	1225 (48.2)	1294 (50.9)	1294 (50.9)
	M	mm (in)	585 (23.0)	600 (23.6)	600 (23.6)
	 CdG K	mm (in)	618 (24.3)	630 (24.8)	618 (24.3)
	 CdG J	mm (in)	561 (22.1)	538 (21.2)	561 (22.1)
	WEIGHT	kg (lbs.)	584 (1289)	635 (1401)	680 (1499)

## Connections

		UNITS	HS-6013 EH030	HS-6017 EH040	HS-6023 EH055
A	CONNECTION	B.S.P thread (NH)	2 x 3/4 (*1)	2 x 3/4 (*1)	2 x 3/4 (*1)
	H	mm (in)	1141 (44.9)	1232 (48.5)	1267 (49.9)
	MIN/MAX PRESSURE	bar (P.S.I)	0.5-6 (7-87)	0.5-6 (7-87)	0.5-6 (7-87)
	RECOMM. PRESSURE	bar (P.S.I)	2-4 (30-60)	2-4 (30-60)	2-4 (30-60)
	FLOW (4 bar)	l/min (Usgal/min)	60 (16)	60 (16)	60 (16)
	MAXIMUM TEMPERATURE	°C (°F)	80 (176)	80 (176)	80 (176)
D	OUTLET HOSE	Ø mm (in)	80 (3.15)	80 (3.15)	80 (3.15)
	H	mm (in)	125 (4.9)	125 (4.9)	175 (6.9)
	N	mm (in)	132 (5.2)	154 (6.1)	29 (1.1)
	P	mm (in)	250 (10)	250 (10)	250 (10)
	DRAIN BOX DIMENSIONS (L,P,H)	mm in	300x300x250(H) 12"x12"x10"(H)	300x300x250(H) 12"x12"x10"(H)	300x300x250(H) 12"x12"x10"(H)
	DRAIN BOX PIPE	Ø mm (in)	100 (4)	100 (4)	100 (4)
E	INLET FASTENING	Ø mm (in)	37 (1 1/2)	37 (1 1/2)	37 (1 1/2)
	H	mm (in)	1005 (39.5)	1165 (45.9)	1129 (44.4)
	N	mm (in)	326 (12.8)	360 (14.2)	429 (16.9)
Ed	INLET FASTENING	Ø mm (in)	16 (0.6)	16 (0.6)	16 (0.6)
	H	mm (in)	1005 (39.5)	1120 (44.1)	1129 (44.4)
	N	mm (in)	226 (10.5)	367 (14.5)	367 (14.5)
	MAXIMUM VOLTAGE	V	240	240	240
	MAXIMUM CURRENT	A	0.05 (*2)	0.05 (*2)	0.05 (*2)
d	CONNECTION	mm (in)	8 x diám,10 (3/8) 1 x diám,12 (1/2)	8 x diám,10 (3/8) 1 x diám,12 (1/2)	8 x diám,10 (3/8) 1 x diám,12 (1/2)
	H	mm (in)	1019 (40.1)	1100 (43.3)	1143 (45.0)
	N	mm (in)	304 (11.9)	340 (13.4)	406 (16)
V	CONNECTION	B.S.P thread (in)	1/2	1/2	1/2
	H	mm (in)	625 (24.6)	626 (24.6)	671 (26.4)
	N	mm (in)	342 (13.4)	384 (15.1)	459 (18.1)
	PRESSURE	bar (P.S.I)	2/6 (29/87)	2/6 (29/87)	2/6 (29/87)
	FLOW	kg/h (lbs/h.)	80 (176)	80 (176)	80 (176)
Vc	INLET FASTENING	Ø mm (in)	16 (0.6)	16 (0.6)	16 (0.6)
	H	mm (in)	1005 (39.5)	1120 (44.1)	1129 (44.4)
	N	mm (in)	226 (10.5)	367 (14.5)	337 (13.3)



	UNITS	HS-6024 EH060	HS-6028 EH070	HS-6032 EH080	
A	CONNECTION	B.S.P thread (NH)	2 x 3/4 (* 1)	2 x 3/4 (* 1)	2 x 3/4 (* 1)
	H	mm (in)	1265 (49.8)	1304 (51.3)	1304 (51.3)
	MIN/MAX PRESSURE	bar (P.S.I)	0.5-6 (7-87)	0.5-6 (7-87)	0.5-6 (7-87)
	RECOMM. PRESSURE	bar (P.S.I)	2-4 (30-60)	2-4 (30-60)	2-4 (30-60)
	FLOW (4 bar)	l/min (Usgal/min)	60 (16)	60 (16)	60 (16)
	MAXIMUM TEMPERATURE	°C (°F)	80 (176)	80 (176)	80 (176)
D	OUTLET HOSE	Ø mm (in)	80 (3.15)	80 (3.15)	80 (3.15)
	H	mm (in)	145 (5.7)	129 (5.1)	129 (5.1)
	N	mm (in)	180 (7.1)	225 (8.9)	225 (8.9)
	P	mm (in)	250 (10)	250 (10)	250 (10)
	DRAIN BOX DIMENSIONS (L,P,H)	mm in	300x300x250(H) 12"x12"x10"(H)	300x300x250(H) 12"x12"x10"(H)	300x300x250(H) 12"x12"x10"(H)
	DRAIN BOX PIPE	Ø mm (in)	100 (4)	100 (4)	100 (4)
E	INLET FASTENING	Ø mm (in)	37 (1 1/2)	37 (1 1/2)	37 (1 1/2)
	H	mm (in)	1160 (45.7)	1177 (46.3)	1177 (46.3)
	N	mm (in)	415 (16.3)	403 (15.9)	403 (15.9)
Ed	INLET FASTENING	Ø mm (in)	16 (0.6)	16 (0.6)	16 (0.6)
	H	mm (in)	1160 (45.7)	1177 (46.3)	1177 (46.3)
	N	mm (in)	359 (14.1)	347 (13.7)	347 (13.7)
	MAXIMUM VOLTAGE	V	240	240	240
	MAXIMUM CURRENT	A	0.05 (*2)	0.05 (*2)	0.05 (*2)
d	CONNECTION	mm (in)	8 x diám,10 (3/8) 1 x diám,12 (1/2)	8 x diám,10 (3/8) 1 x diám,12 (1/2)	8 x diám,10 (3/8) 1 x diám,12 (1/2)
	H	mm (in)	1155 (45.5)	1174 (46.2)	1174 (46.2)
	N	mm (in)	393 (15.5)	412 (16.2)	412 (16.2)
V	CONNECTION	B.S.P thread (in)	1/2	1/2	1/2
	H	mm (in)	610 (24.0)	620 (24.4)	620 (24.4)
	N	mm (in)	430 (16.9)	469 (18.5)	469 (18.5)
	PRESSURE	bar (P.S.I)	2/6 (29/87)	2/6 (29/87)	2/6 (29/87)
	FLOW	kg/h (lbs/h.)	80 (176)	80 (176)	80 (176)
Vc	INLET FASTENING	Ø mm (in)	16 (0.6)	16 (0.6)	16 (0.6)
	H	mm (in)	1160 (45.7)	1177 (46.3)	1177 (46.3)
	N	mm (in)	311 (12.2)	299 (11.8)	299 (11.8)

Legend

CONNECTIONS	
A	Water supply
D	Drain
E	Electrical connection inlet
Ed	Electrical connection inlet external dosing
d	Product inlets external dosing
V	Steam inlet connection
Vc	Vending connection inlet (not applicable to USA/CANADA models)
* 1	INTELI CONTROL: option 3 x 3/4 in
* 2	Origin of the external dosing signal to the washer 1A maximum current

DIMENSIONS (Figures 1, 2 & 3)	
H	Height from the machine base
N	Distance from the centre of symmetry of the unit
P	Depth
M	Height to door bottom
	Gravity centre (GC)

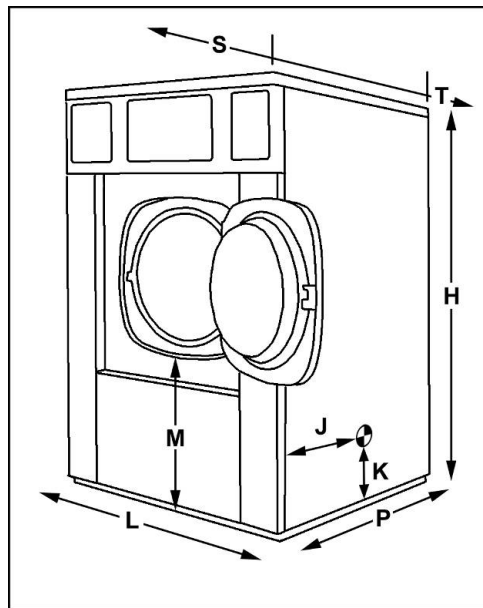

Fig. 1.1

HS-6013/17/23 / EH030/040/055

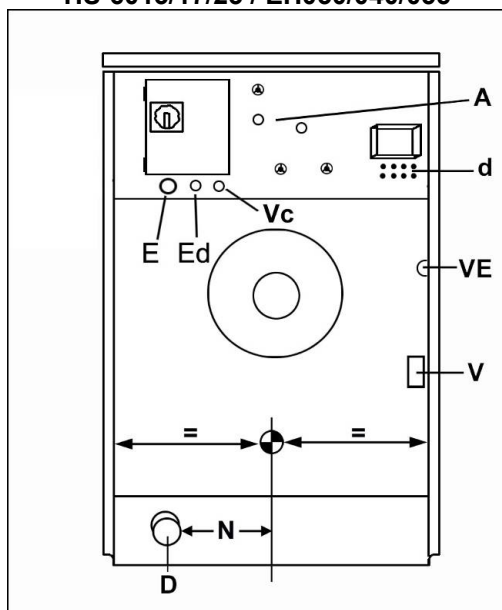

Fig. 1.2

HS-6024/28/32 / EH060/070/080

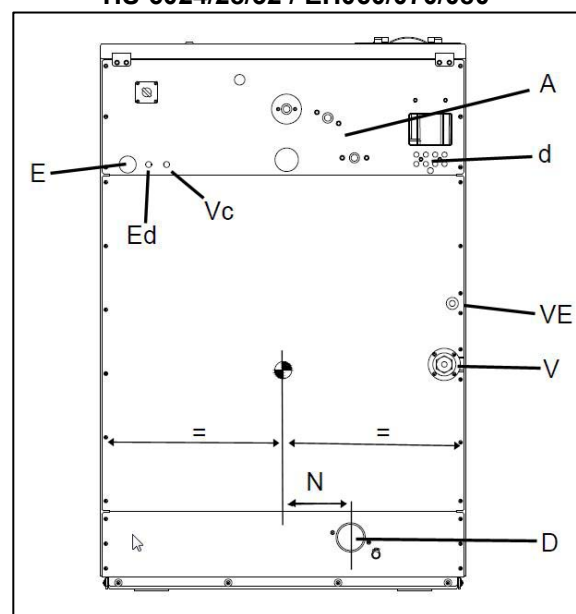

Fig. 1.3

## Environment and positioning conditions

MAXIMUM TEMPERATURE		°C (°F)	+41 (+104)
MINIMUM TEMPERATURE		°C (°F)	+5 (+40)
LIGHTING		Lux	300
VENTING OPENING		cm <sup>2</sup> (sq.ft.)	300 (0.4)
MAXIMUM RELATIVE HUMIDITY		%	90
<b>S</b>	WORKING AREA	mm (in)	1000 (39.4)
<b>T</b>	REAR MAINTENANCE AREA (*3)	mm (in)	500 (19.7)

\*3. Double drain kit washers: figure **T** must measure 600 mm (23.6 inch) minimum  
 If the installation calls for more than one washer, please refer to the corresponding dimensions in section 2.5 and figure 2.3

## 1.5. Connection table explanation

Connection table explanation and symbols of section 1.6.

(*1) HEATING		
<b>H</b>	Without heating	
<b>V</b>	Steam heating	
<b>E</b>	Electric heating	
	<b>red.</b>	reduced power
	<b>norm.</b>	normal power

(*2) EXPLANATION OF WIRE VALUES	
<b>A</b> x <b>B</b> + <b>N</b> +	Wire details in mm <sup>2</sup>
<b>(A</b> x <b>B</b> + <b>GND</b> )	(USA/CANADA: wire details in AWG)
A x <b>B</b> + <b>N</b> +	Wire number
A x B + <b>N</b> +	Neutral wire
A x B + <b>N</b> +	Ground
<b>(A</b> x <b>B</b> + <b>GND</b> )	(USA/CANADA: ground wire)
<p><b>USE COPPER CONDUCTORS ONLY</b>                      The machine shall be connected only to a supply circuit to which no lighting units or general-purpose receptacles are connected.</p>	

**1.6. Electrical requirements**

Check table explanation in section 1.5.



In brackets: USA / CANADA specific values

**HS-6013 / EH030**

VOLTAGE	HEATING (*1)		TOTAL POWER	TOTAL CONSUMP.	SWITCH CURRENT	CONDUCTOR (*2)
			kW	A	A	mm <sup>2</sup> (AWG)
200V 1ph + N 2ph	H / V		0.87	4.4	6	1.5 x 2 +
	E	red.	4.6	22.9	32	6 x 2 +
		norm.	6.0	29.9	40	10 x 2 +
208V 1ph + N 2ph	H / V		0.87	4.2	6	1.5 x 2 +
			(0.87)	(4.2)	(10)	(16 x 2 + GND)
	E	red.	4.9	23.7	32	6 x 2 +
		norm.	6.4	30.9	40	10 x 2 +
			(6.4)	(30.9)	(40)	(6 x 2 + GND)
220V 1ph + N 2ph	H / V		0.87	4.0	6	1.5 x 2 +
	E	red.	5.5	24.8	40	6 x 2 +
		norm.	7.1	32.5	50	10 x 2 +
230V 1ph + N 2ph	H / V		0.87	3.8	6	1.5 x 2 +
	E	red.	5.9	25.8	40	6 x 2 +
		norm.	7.8	33.8	50	10 x 2 +
240V 1ph + N 2ph	H / V		0.87	3.6	6	1.5 x 2 +
			(0.87)	(3.6)	(10)	(16 x 2 + GND)
	E	red.	6.4	26.8	40	6 x 2 +
		norm.	8.4	35.1	50	10 x 2 +
			(8.4)	(35.1)	(50)	(6 x 2 + GND)
200V 3ph	E	red.	6.7	20.1	32	6 x 3 +
		norm.	8.8	26.2	40	6 x 3 +
208V 3ph	E	red.	7.2	20.8	32	6 x 3 +
		norm.	9.4	27.0	40	6 x 3 +
			(9.4)	(27.0)	(40)	(8 x 3 + GND)
220V 3ph	E	red.	8.0	21.8	32	6 x 3 +
		norm.	10.5	28.4	40	6 x 3 +
230V 3ph	E		8.7	22.6	32	6 x 3 +
			11.4	29.5	40	6 x 3 +
240V 3ph	E	red.	9.4	23.4	32	6 x 3 +
		norm.	12.4	30.6	40	6 x 3 +
			(12.4)	(30.6)	(40)	(8 x 3 + GND)
380V 3ph + N	E	red.	7.9	13.3	20	4 x 3 + N +
		norm.	10.4	17.1	25	4 x 3 + N +
400V 3ph + N	E	red.	8.8	13.9	20	4 x 3 + N +
		norm.	11.5	17.9	25	4 x 3 + N +
415V 3ph + N	E	red.	9.4	14.2	20	4 x 3 + N +
		norm.	12.4	18.4	25	4 x 3 + N +

! Check table explanation in section 1.5.

! In brackets: USA / CANADA specific values

**HS-6017 / EH040**

VOLTAGE	HEATING (*1)		TOTAL POWER	TOTAL CONSUMP.	SWITCH CURRENT	CONDUCTOR (*2)
			kW	A	A	mm <sup>2</sup> (AWG)
200V 1ph + N 2ph	H / V		1.3	6.5	10	1.5 x 2 +
	E	red.	4.8	23.9	32	6 x 2 +
		norm.	7.6	37.8	50	10 x 2 +
208V 1ph + N 2ph	H / V		1.3	6.3	10	1.5 x 2 +
			(1.3)	(6.3)	(10)	(16 x 2 + GND)
	E	red.	5.1	24.6	32	6 x 2 +
		norm.	8.1	39.1	50	10 x 2 +
		(8.1)	(39.1)	(45)	(6 x 2 + GND)	
220V 1ph + N 2ph	H / V		1.3	5.9	10	1.5 x 2 +
	E	red.	5.7	25.7	40	6 x 2 +
		norm.	9.0	41.0	63	10 x 2 +
230V 1ph + N 2ph	H / V		1.3	5.7	10	1.5 x 2 +
	E	red.	6.1	26.7	40	6 x 2 +
		norm.	9.8	42.6	63	10 x 2 +
240V 1ph + N 2ph	H / V		1.3	5.4	10	1.5 x 2 +
			(1.3)	(5.4)	(10)	(16 x 2 + GND)
	E	red.	6.6	27.6	40	6 x 2 +
		norm.	10.6	44.3	63	10 x 2 +
		(10.6)	(44.3)	(60)	(6 x 2 + GND)	
200V 3ph	E	red.	6.9	21.1	32	6 x 3 +
		norm.	11.0	33.2	50	10 x 3 +
208V 3ph	E	red.	7.4	21.7	32	6 x 3 +
		norm.	11.9	34.3	50	10 x 3 +
			(11.9)	(34.3)	(40)	(6 x 3 + GND)
220V 3ph	E	red.	8.2	22.7	32	6 x 3 +
		norm.	13.2	35.9	50	10 x 3 +
230V 3ph	E	red.	8.9	23.4	32	6 x 3 +
		norm.	14.4	37.3	50	10 x 3 +
240V 3ph	E	red.	9.6	24.2	32	6 x 3 +
		norm.	15.6	38.7	50	10 x 3 +
			(15.6)	(38.7)	(50)	(6 x 3 + GND)
380V 3ph + N	E	red.	8.1	14.2	20	4 x 3 + N +
		norm.	13.2	21.9	32	6 x 3 + N +
400V 3ph + N	E	red.	9.0	14.7	20	4 x 3 + N +
		norm.	14.5	22.7	32	6 x 3 + N +
415V 3ph + N	E	red.	9.6	15.1	20	4 x 3 + N +
		norm.	15.6	23.4	32	6 x 3 + N +

- Check table explanation in section 1.5.
- In brackets: USA / CANADA specific values

**HS-6023 / EH055 3Ph**

VOLTAGE	HEATING (*1)	TOTAL POWER	TOTAL CONSUMP.	SWITCH CURRENT	CONDUCTOR (*2)	
		kW	A	A	mm <sup>2</sup> (AWG)	
200V 3ph	H / V	1.75	5.1	6	1.5 x 3 +	
	E	red.	9.0	25.9	40	6 x 3 +
		norm.	14.2	41.0	63	10 x 3 +
208V 3ph	H / V	1.75	4.9	6	1.5 x 3 +	
		(1.75)	(4.9)	(6)	(16 x 3 + GND)	
	E	red.	9.7	26.8	40	6 x 3 +
		norm.	15.3	42.7	63	10 x 3 +
		(15.4)	(42.7)	(63)	(6 x 3 + GND)	
220V 3ph	H / V	1.75	4.6	6	1.5 x 3 +	
	E	red.	10.7	28.2	40	6 x 3 +
		norm.	17.0	44.7	63	10 x 3 +
230V 3ph	H / V	1.75	4.4	6	1.5 x 3 +	
	E	red.	11.7	29.3	40	6 x 3 +
		norm.	18.6	46.6	63	10 x 3 +
240V 3ph	H / V	1.75	4.2	6	1.5 x 3 +	
		(1.75)	(4.2)	(6)	(16 x 3 + GND)	
	E	red.	12.8	30.8	40	6 x 3 +
		norm.	20.3	48.8	63	10 x 3 +
		(20.3)	(48.8)	(63)	(6 x 3 + GND)	
380V 3ph	H / V	1.75	2.7	6	1.5 x 3 +	
	E	red.	10.7	16.2	25	4 x 3 +
		norm.	16.9	25.7	40	6 x 3 +
400V 3ph	H / V	1.75	2.5	6	1.5 x 3 +	
	E	red.	11.8	17.0	25	4 x 3 +
		norm.	18.7	27.0	40	6 x 3 +
415V 3ph	H / V	1.75	2.4	6	1.5 x 3 +	
	E	red.	12.8	17.8	25	4 x 3 +
		norm.	20.2	28.1	40	6 x 3 +
440V 3ph	H / V	1.75	2.3	6	1.5 x 3 +	
480V 3ph	H / V	1.75	2.1	6	1.5 x 3 +	



Check table explanation in section 1.5.



In brackets: USA / CANADA specific values

**HS-6023 / EH055 1Ph**

VOLTAGE	HEATING (*1)	TOTAL POWER	TOTAL CONSUMP.	SWITCH CURRENT	CONDUCTOR (*2)
		kW	A	A	mm <sup>2</sup> (AWG)
200V 1ph + N 2ph	H / V	1.75	9.0	16	2.5 x 2 +
208V 1ph + N 2ph	H / V	1.75	7.8	16	2.5 x 2 +
		(1.75)	(7.8)	(16)	(12 x 2 + GND)
220V 1ph + N 2ph	H / V	1.75	7.6	16	2.5 x 2 +
230V 1ph + N 2ph	H / V	1.75	7.4	16	2.5 x 2 +
240V 1ph + N 2ph	H / V	1.75	7.0	16	1.5 x 2 +
		(1.75)	(7.0)	(16)	(12 x 2 + GND)

Check table explanation in section 1.5.

In brackets: USA / CANADA specific values

**HS-6024 / EH060 3Ph**

VOLTAGE	HEATING (*1)	TOTAL POWER	TOTAL CONSUMP.	SWITCH CURRENT	CONDUCTOR (*2)	
		kW	A	A	mm <sup>2</sup> (AWG)	
200V 3ph	H / V	1.88	5.4	10	2.5 x 3 +	
	E	red.	9.1	26.2	40	10 x 3 +
		norm.	14.3	41.3	63	25 x 3 +
208V 3ph	H / V	1.88	5.2	10	2.5 x 3 +	
		(1.88)	(5.2)	(15)	(12 x 3 + GND)	
	E	red.	9.8	27.1	40	10 x 3 +
		norm.	15.5	43.0	63	25 x 3 +
		(15.5)	(43.0)	(50)	(6 x 3 + GND)	
220V 3ph	H / V	1.88	4.9	10	2.5 x 3 +	
	E	red.	10.8	28.4	40	10 x 3 +
		norm.	17.1	45.0	63	25 x 3 +
230V 3ph	H / V	1.88	4.7	10	2.5 x 3 +	
	E	red.	11.8	29.5	40	10 x 3 +
		norm.	18.7	46.8	63	25 x 3 +
240V 3ph	H / V	1.88	4.5	10	2.5 x 3 +	
		(1.88)	(4.5)	(15)	(12 x 3 + GND)	
	E	red.	12.9	31.1	40	10 x 3 +
		norm.	20.4	49.0	63	25 x 3 +
		(20.4)	(49.0)	(60)	(4 x 3 + GND)	
380V 3ph	H / V	1.88	2.9	6	2.5 x 3 +	
	E	red.	10.8	16.4	25	4 x 3 +
		norm.	17.0	25.9	40	10 x 3 +
400V 3ph	H / V	1.88	2.7	6	2.5 x 3 +	
	E	red.	11.9	17.1	25	4 x 3 +
		norm.	18.8	27.1	40	10 x 3 +
415V 3ph	H / V	1.88	2.6	6	2.5 x 3 +	
	E	red.	12.9	17.9	25	4 x 3 +
		norm.	20.3	28.3	40	10 x 3 +
440V 3ph	H / V	1.88	2.5	6	2.5 x 3 +	
		(1.88)	(2.5)	(10)	(12 x 3 + GND)	
480V 3ph	H / V	1.88	2.3	6	2.5 x 3 +	
		(1.88)	(2.5)	(10)	(12 x 3 + GND)	



- ! Check table explanation in section 1.5.
- ! In brackets: USA / CANADA specific values
- ! Connection to power supply  $I_{eq}=16A$   $R_{sce}=250$  in accordance with UNE EN 61000-3-12:2012
- !  $Z_{min} : (0.165+j0.109)$  Ohm EN 61000-3-11:2000

### HS-6024 / EH060 1Ph

VOLTAGE	HEATING (*1)	TOTAL POWER	TOTAL CONSUMP.	SWITCH CURRENT	CONDUCTOR (*2)
		kW	A	A	mm <sup>2</sup> (AWG)
200V 1ph + N 2ph	H / V	1.88	10.5	16	2.5 x 2 +
208V 1ph + N 2ph	H / V	1.88	10.1	16	2.5 x 2 +
		(1.88)	(10.1)	(15)	(12 x 2 + GND)
220V 1ph + N 2ph	H / V	1.88	9.5	16	2.5 x 2 +
230V 1ph + N 2ph	H / V	1.88	9.1	16	2.5 x 2 +
240V 1ph + N 2ph	H / V	1.88	8.8	16	2.5 x 2 +
		(1.88)	(8.8)	(15)	(12 x 2 + GND)

Check table explanation in section 1.5.

In brackets: USA / CANADA specific values

**HS-6028 / EH070 3Ph**

VOLTAGE	HEATING (*1)	TOTAL POWER	TOTAL CONSUMP.	SWITCH CURRENT	CONDUCTOR (*2)
	Type	kW	A	A	mm2 (AWG)
200V 3ph	H/V	3.0	8.7	10	2.5 x 3 +
	E	14.7	42.4	50	16 x 3 +
208V 3ph	H/V	3.0	8.4	10	2.5 x 3 +
				(10)	(14 x 3 + GND)
	E	15.8	43.8	63	25 x 3 +
				(60)	(4 x 3 + GND)
220V 3ph	H/V	3.0	7.9	10	2.5 x 3 +
	E	17.5	46	63	25 x 3 +
230V 3ph	H/V	3.0	7.6	10	2.5 x 3 +
	E	19.1	47.8	63	25 x 3 +
240V 3ph	H/V	3.0	7.2	10	2.5 x 3 +
				(10)	(14 x 3 + GND)
	E	20.7	49.7	63	25 x 3 +
				(60)	(4 x 3 + GND)
380V 3ph	H/V	3.0	4.6	6	2.5 x 3 +
	E	17.5	26.5	32	10 x 3 +
400V 3ph	H/V	3.0	4.3	6	2.5 x 3 +
	E	19.2	27.7	32	10 x 3 +
415V 3ph	H/V	3.0	4.2	6	2.5 x 3 +
	E	20.6	28.6	40	10 x 3 +
440V 3ph	H/V	3.0	3.9	6	2.5 x 3 +
				(10)	(14 x 3 + GND)
480V 3ph	H/V	3.0	3.6	6	2.5 x 3 +
				(10)	(14 x 3 + GND)

! Check table explanation in section 1.5.

! In brackets: USA / CANADA specific values

**HS-6032 / EH080 3Ph**

VOLTAGE	HEATING (*1)	TOTAL POWER	TOTAL CONSUMP.	SWITCH CURRENT	CONDUCTOR (*2)
	Type	kW	A	A	mm2 (AWG)
200V 3ph	H/V	4.2	12.1	16	2.5 x 3 + ⊕
	E	14.7	42.4	50	16 x 3 + ⊕
208V 3ph	H/V	4.2	11.7	16	2.5 x 3 + ⊕
				(10)	(12 x 3 + GND)
	E	15.8	43.9	63	25 x 3 + ⊕
				(60)	(6 x 3 + GND)
220V 3ph	H/V	4.2	11	16	2.5 x 3 + ⊕
	E	17.5	46	63	25 x 3 + ⊕
230V 3ph	H/V	4.2	10.5	16	2.5 x 3 + ⊕
	E	19.1	47.9	63	25 x 3 + ⊕
240V 3ph	H/V	4.2	10.1	16	2.5 x 3 + ⊕
				(10)	(12 x 3 + GND)
	E	20.7	49.7	63	25 x 3 + ⊕
				(60)	(4 x 3 + GND)
380V 3ph	H/V	4.2	6.4	8	2.5 x 3 + ⊕
	E	17.5	26.5	32	10 x 3 + ⊕
400V 3ph	H/V	4.2	6.1	8	2.5 x 3 + ⊕
	E	19.2	27.7	32	10 x 3 + ⊕
415V 3ph	H/V	4.2	5.8	8	2.5 x 3 + ⊕
	E	20.6	28.7	40	10 x 3 + ⊕
440V 3ph	H/V	4.2	5.5	8	2.5 x 3 + ⊕
				(10)	(12 x 3 + GND)
480V 3ph	H/V	4.2	5.1	6	2.5 x 3 + ⊕
				(10)	(12 x 3 + GND)

## 2. RECEIPT, TRANSPORT AND LOCATION

### 2.1. Receipt

The following should be checked on accepting delivery of the washer:

- Check that the product has not suffered any damage in transit. (Any damage caused in this way will not be attributable to the manufacturer, and the appropriate claim should be made against the party responsible for transporting the product.)
- Check that the delivered machine fulfils the requirements requested in the order: **MODEL, VOLTAGE, FREQUENCY AND TYPE OF HEATING.**

**THE MACHINE'S PACKAGING MUST BE DISPOSED OF IN ACCORDANCE WITH THE ENVIRONMENTAL REGULATIONS IN FORCE IN THE COUNTRY OR AREA IN WHICH THE MACHINE IS TO BE USED.**

### 2.2. Transport of the machine



**IT IS BOUND THAT ALL MANOEUVRES ARE CARRIED OUT BY STAFF SPECIALISED IN TRANSPORT. ALWAYS USE TRANSPORT METHODS WHICH ARE SUITABLE FOR THE WEIGHT AND VOLUME OF THE WASHER. CHECK THE VALUES ON THE PACKAGING AND THE INSTALLATION SPECS (section 1.4) OF THIS MANUAL.**

- Before moving the washer, check the instructions of the packaging pictograms.
- Unit must be transported in the upright position.
- Protect the machine from rain and dampness.
- Avoid blows and shocks.
- It is preferable to transport the washer with its packaging using a forklift and by lifting it from its base. Never move the machine by pushing on the sides of the packaging.
- Position the washer with crating as near as possible to the final location.

#### **HS-6023; EH055**

This model has lifting handles located at the outer drum top which allows lifting the machine with a crane.

Unlock the upper cover and remove it to access the lifting handles. (Fig. 2.1)

Replace and lock the top cover correctly, when the installation is finished.

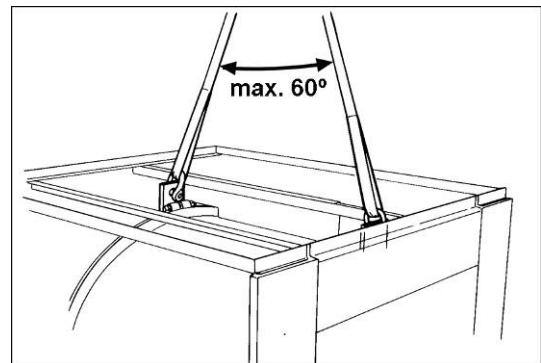

Fig. 2.1

### 2.3. Safety door unlock (HS-6023, HS-6024, HS-6028, HS-6032, EH055, EH060, EH070, EH080 models only)

To open the door in case of power failure, completely insert a rod of a diameter of 0.2 in (3 mm) and an approximate length of 4 inches (100 mm) into the bottom side of the safety lock cover, and at the same time turn the knob downwards. (Fig. 2.2)

 **WARNING!**

**MANUAL OPENING OF THE SAFETY LOCK MUST ONLY BE USED BEFORE THE START-UP OF THE MACHINE. ONCE THE WASHER IS IN SERVICE, NEVER USE THE MANUAL OPENING OF THE LOCK AS A USUAL WAY TO OPEN THE DOOR.**

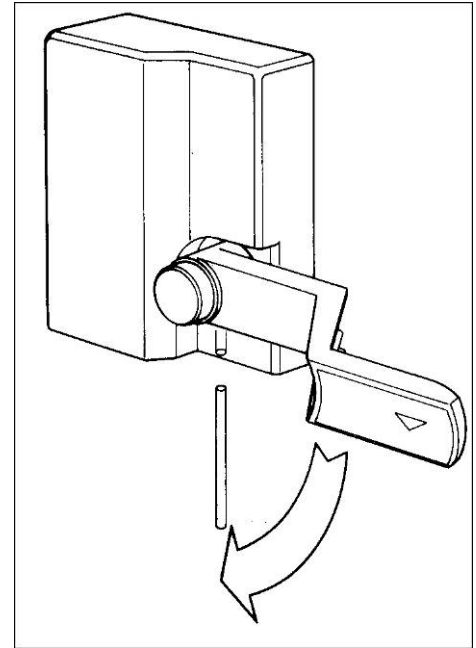

Fig. 2.2

### 2.4. Washer location Conditions

 **INSTALLATION ON UPPER FLOORS**

Never install washing machines on suspended floors or above ground level without obtaining approval from the appropriate qualified technician (structural engineer for building safety and noise transmission).

See floor static & dynamic strength requirements on **INSTALLATION SPECIFICATIONS** (section 1.4).

In these installations, the manufacturer declines all responsibility for possible damages caused by vibrations in the building structures.

The floor of the washer location must be a flat surface (refer to the indications on the **INSTALLATION SPECS**, section 1.4) capable of supporting the weight of the washer without becoming distorted.

**It is recommended a concrete location of RECOMMENDED MINIMUM RESISTANCE equal to or greater than 250kg/cm<sup>2</sup> (4000 psi)**

Respect the **ENVIRONMENTAL CONDITIONS** indicated on the **INSTALLATION SPECS** (section 1.4). Also, respect the work and maintenance areas; these are necessary for the safe use and appropriate maintenance of the washing machine.

Do not install the washer in improper vented areas. The products used can produce steam and gas products emissions, which in high concentrations can be very dangerous to health.



TO REDUCE VIBRATION AND SOUND AND TO ENSURE THAT THE MACHINE IS CORRECTLY BALANCED, IT IS ESSENTIAL THAT THE FOUR BASE LEGS OF THE WASHING MACHINE REST UNIFORMLY UPON THE FLOOR. DO NOT PLACE ANY TYPE OF ANTI-VIBRATORY DEVICE BETWEEN THE WASHER AND THE FLOOR.



NEVER INSTALL THE WASHER OVER AREAS BUILT WITH COMBUSTIBLE MATERIAL.  
IF WASHERS ARE INSTALLED ON METALLIC SURFACES, AN ELECTRICAL CONDUCTOR INDEPENDENT TO THE WASHER GROUND MUST GROUND THESE SURFACES.



**Specific warning for appliances installed IN THE USA /CANADA.**

To reduce the risk of fire, this appliance must be fastened or otherwise secured to an uncovered concrete floor.

Alternatively the appliance should stand on a metal plate, at least the same size as the appliance and minimum thickness of 1/16 inch.

**2.5. Installing more than one washer**

If the installation calls for more than one washer, align them with each other.

The minimum distance between adjacent machines and the user and maintenance areas (values **I**, **S** and **T** of Figure 2.3) are specified on the table below.

Check the dimensions of the drain box and the drain pipe on the table below.

**Positioning conditions (Fig. 2.3)**

<b>I</b>	DISTANCE BETWEEN MACHINES (RECOMMENDED) (Commercial and Industrial laundries)	mm (in)	100 - 250 (4 - 10)
	DISTANCE BETWEEN MACHINES (MINIMUM) (Coin-op laundries)	mm (in)	10 (0.4)
<b>S</b>	WORKING AREA	mm (in)	1000 (39.4)
<b>T</b>	REAR MAINTENANCE AREA (*1)	mm (in)	500 (19.7)
<b>A</b>	DRAIN BOX	mm in	300 x 300 x 250 (H) 12" x 12" x 10" (H)
∅	DRAIN PIPE (∅x1; ∅x2; ∅x3)	∅ mm (in)	100; 150; 180 (4; 6; 7)

\*1. Double drain kit washers: figure **T** must measure 600 mm (23.6 inch) minimum

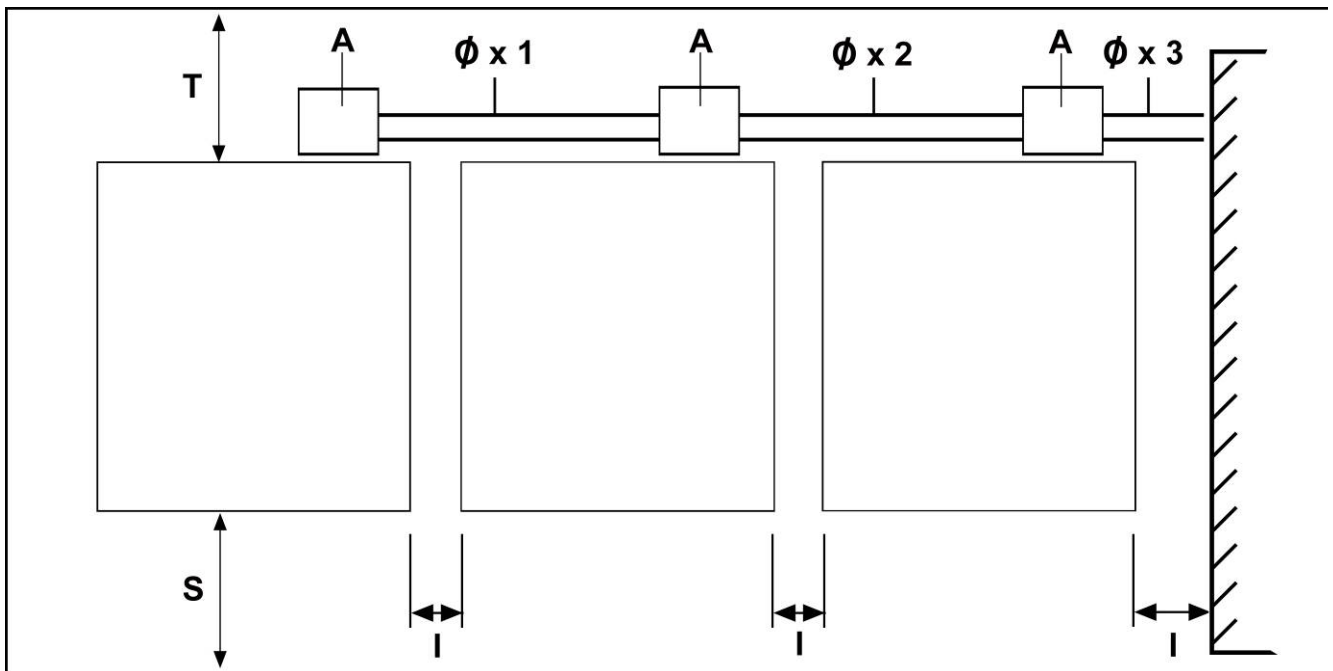

Fig. 2.3

## 2.6. Removal of shipping braces



**DO NOT REMOVE THE SHIPPING RESTRAINTS BEFORE PLACING THE WASHER IN ITS DEFINITIVE POSITION.  
NEVER START THE MACHINE UP WITHOUT FIRST REMOVING THE SHIPPING RESTRAINTS. INCOMPLIANCE WITH THIS PRECAUTION MAY CAUSE SERIOUS PHYSICAL DAMAGES TO PEOPLE AND IRREPARABLE DAMAGES TO THE WASHER. THE WARRANTY DOES NOT COVER THIS INCIDENCE.**

### 2.6.1. HS-6013, HS-6017, HS-6024, HS-6028, HS-6032, EH030, EH040, EH060, EH070, EH080 models

Steps to follow (Fig. 2.4 and 2.5).

- Disassemble the lower cover **A**, by removing screws **B**.
- Remove the two yellow pieces **C** by removing screws **D**.
- Assemble the lower cover and fasten the toe plate (if any) with screws **B**.
- Disassemble the centre rear cover
- Remove the two yellow pieces **E** by removing screws **F**.
- On machines with steam heating, cut the fastening clip of the solenoid valve coil; pull back the coil towards the machine exterior and fasten the coupling for the electrical installation to cut out **VE** on the rear cover (refer Fig. 1.2).
- Assemble the rear cover and secure with the corresponding screws.
- Save the shipping braces. If the washer ever needs to be moved to another location, replace the transport system reversing the steps described in this section.

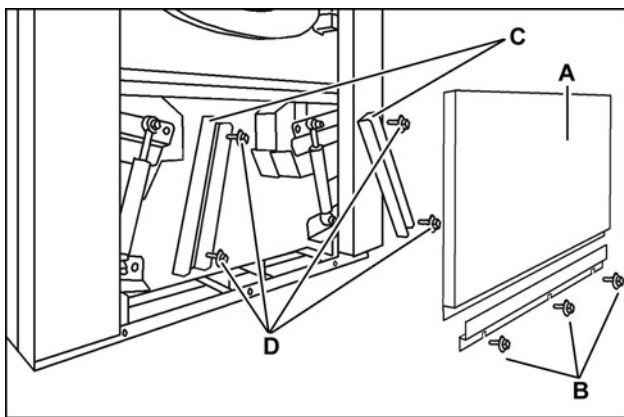

Fig. 2.4

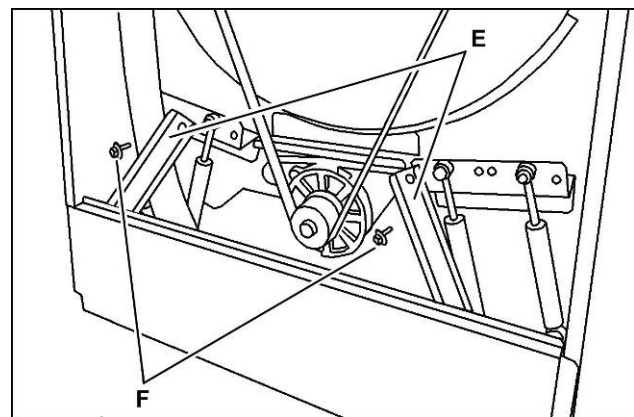

Fig. 2.5



### CAUTION!

The rubber profile is a protection against cutting and catching. Check that it is properly fixed on the front cover and side covers.



### 2.6.2. HS-6023, EH055 models

- Remove the screws (**Fig. 2.6/A**) holding the lower front cover and loosen the three screws (**Fig. 2.6/B**) holding the base of the chassis.
- Separate the rubber profile (**Fig. 2.6/C**) at the two small side guards and remove the front cover (**Fig. 2.6**).
- Remove the screws holding the rear cover and remove it.
- Locate on the chassis base the two yellow fixing profiles and dismantle them. The profiles are secured with screws (**Fig. 2.7**).
- Assemble the rear cover.
- Assemble the front cover and place the rubber profile at the small side guards.



#### CAUTION!

The rubber profile is a protection against cutting and catching. Check that it is properly fixed on the front cover and side covers.

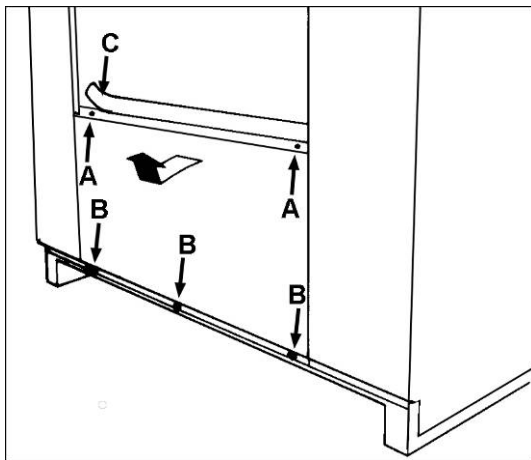

Fig. 2.6

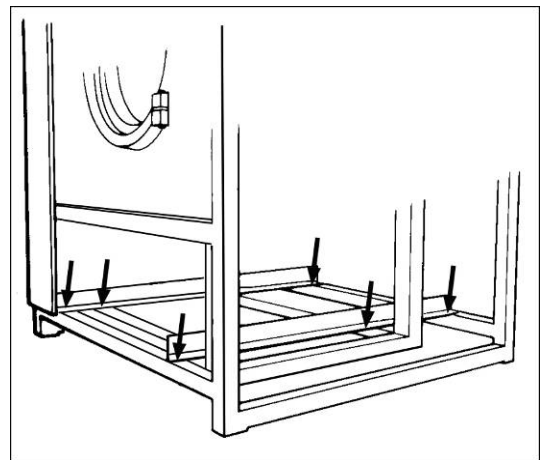

Fig. 2.7

- Assemble the toe plate (Fig. 2.8). This piece is shipped disassembled from the machine.
- Fit the perforated metal plate onto the lower aperture at the back of the machine.
- Both protections are dispatched dismantled from the rest of the machine, and the securing screws are screwed into the respective securing points.

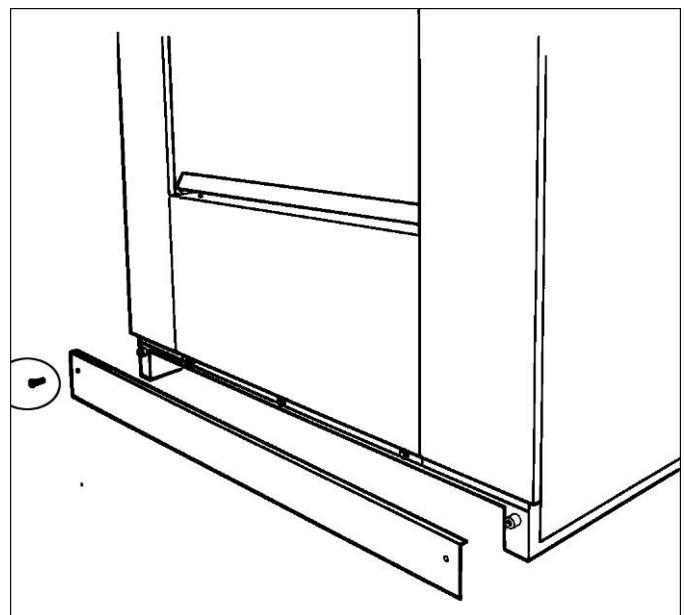

Fig. 2.8

### 3. INSTALLATION



ALL CONNECTIONS FOR ELECTRICAL POWER AND PLUMBING MUST COMPLY WITH THE STATUTORY SAFETY STANDARDS APPLICABLE TO EACH COUNTRY, AND BE MADE BY AUTHORISED INSTALLATION CONTRACTORS ONLY.  
ALL THE WASHER CONNECTIONS MUST BE CARRIED OUT BY THE AUTHORIZED TECHNICAL SERVICE.

#### 3.1. Drain



##### OBSERVATIONS REGARDING THE DRAIN PIPE

Always fit the drain pipe supplied by the manufacturer.  
As a safety measure, the drain elbow pipe must not be modified.

Choose one of the following options depending on the possibilities for installation and the regulations in force in the country where the installation is being carried out.

##### Drain to the drain box

Remove the screws (Fig. 3.1) following the specifications indicated in the INSTALLATION SPECS, section 1.4. Connect the drain elbow to the drain outlet and secure hose with the corresponding clamp (Fig. 3.2).

Do not sink the free end of the drain elbow in the drain box:

- To prevent dirty water siphoning to the washing machine.
- To facilitate the water drain.
- To detect water leaks through the drain.
- To prevent dirty water from coming into contact with the washer.

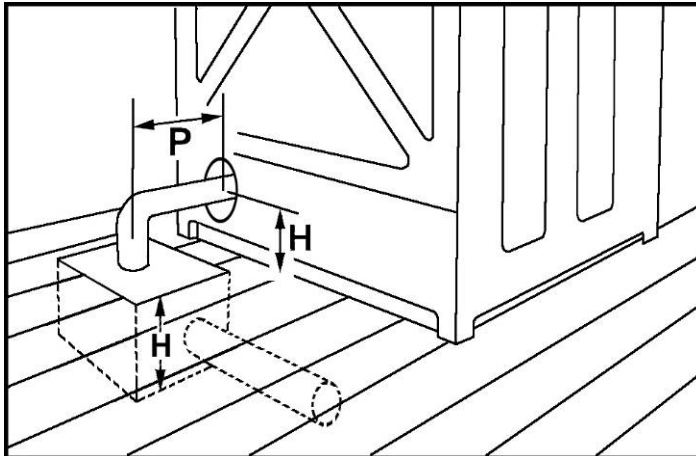

Fig. 3.1

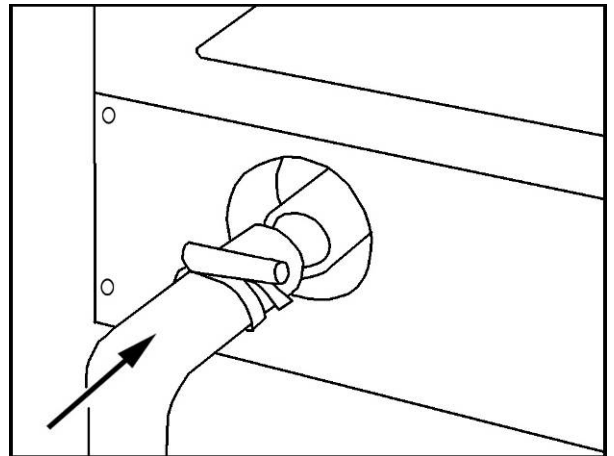

Fig. 3.2

**Direct connection of the washer drain to the manifold (Fig. 3.3)**

Facilities preferring this option to the open box option (recommended option) must respect the following precautions:

Provide next to the connection point of each machine to the manifold, with a manifold ventilation outlet **A** reaching the outside, set at a height of 40 in (1000 mm) and of a diameter of 2 in (50 mm).

Diameter of **B** manifold: refer to table on section 2.5.

The emptying of the drain trap to the sewer system is done through an open drain box (**Fig. 3.3/B and C**) which prevents variations in pressure and backflow to the drain. **The end of the drain trap must not be sunk in the box.**

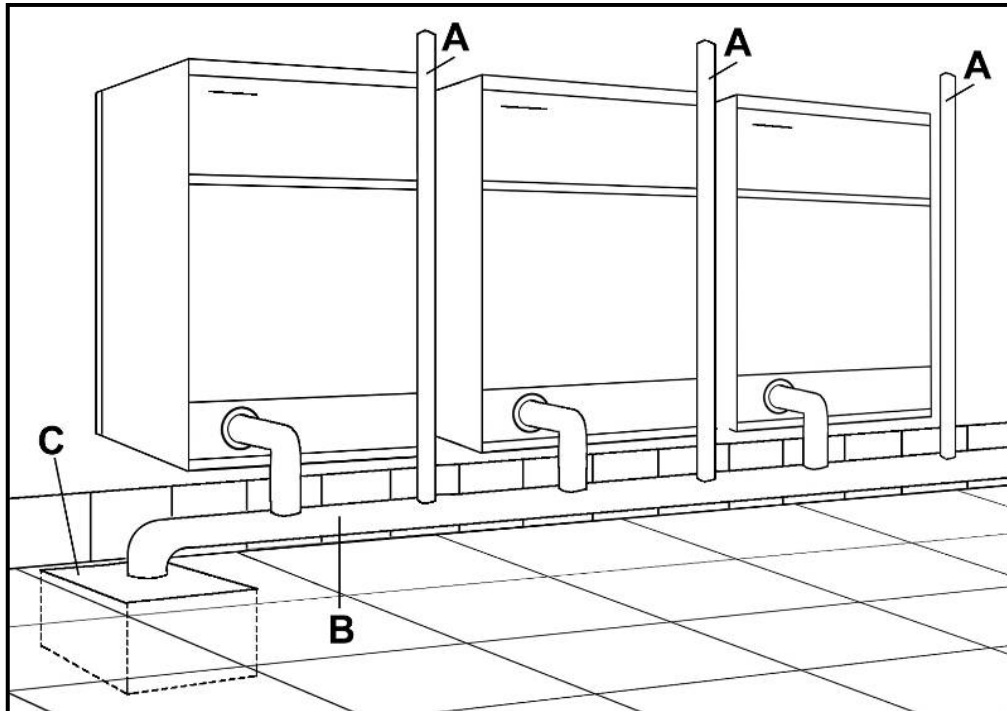

Fig. 3.3

**3.2. Water supply**



**IMPORTANT!**

The local or national regulations concerning the water supply system in the country where the washing machine is installed must be followed.

Hoses and pipes should be flushed through before being connected to the machine.

Install at each water supply and in an accessible location, a mechanically interlocked water valve.

In those premises using water containing impurities, it is recommended to install a filter at the main water supply inlet.

Refer to technical specifications on the INSTALLATION SPECS, section 1.4.

**Assembling the filters and their connection (Fig. 3.4)**

Insert filter **C** and washer **B** inside each of the water inlet couplings **D**.

Assemble the couplings to the solenoid valves **A**.

Place the **E** seals on the water inlet hoses **F**.

Put the water inlet hoses on the solenoid valve couplings.

Open the manual valves and check for leaks in the installation.

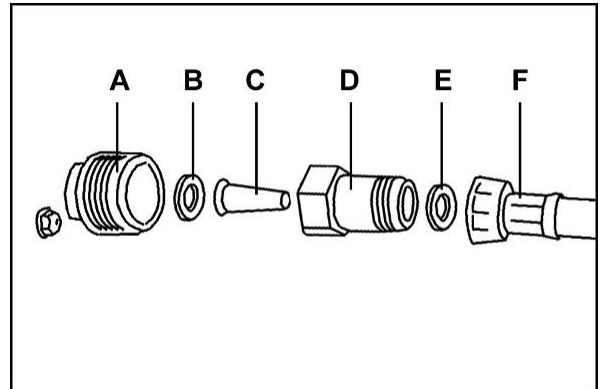

Fig. 3.4

**Arrangement of the hoses**

The inlets are identified by the label posted at each inlet (Fig. 3.5).

The washer mixes hot and cold water according to the temperature programmed. The use of hot/cold water allows the machine to gain time and effectiveness in its washing programs.

**Inlet 1** **1**

The cold water must **ALWAYS** be connected. The hose is marked with a blue line.

**Inlet 2** **2**

Connect hot water. The hose is marked with a red line.

**Inlet 3** **3**

(This option is only available for Inteli Control). Connect cold or hot water according to the washer configuration. The hose is marked with a red line.

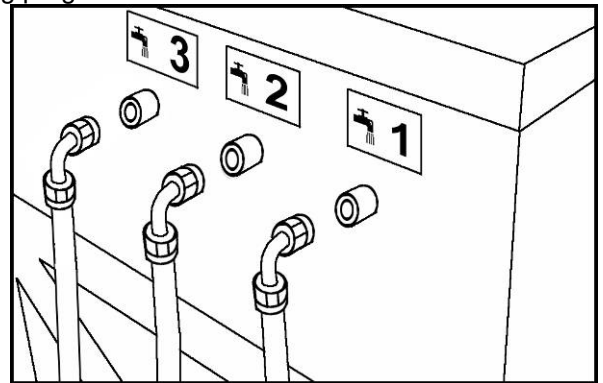

Fig. 3.5



**DO NOT CONNECT THE HOT WATER TO INLET 1. THIS INLET DOES NOT HAVE A TEMPERATURE CONTROL SYSTEM.**  
**DO NOT CONNECT THE HOT WATER TO INLET 3 IF IT IS NOT CONFIGURED AS A DUAL HOT WATER INLET FLOW.**  
**INCOMPLIANCE OF THIS PRECAUTION CAN CAUSE FABRIC DAMAGE.**



**For a correct operation of the washing machine, the hot and cold water inlets must receive an uninterrupted supply at all times.**

**If there is no hot water supply, connect cold water or cold softened water to inlet 2.**

**INTELI control washing machines, ADAPT THE WASHER CONFIGURATION to operate with cold water.**

### Assembling the connection couplings for AUSTRALIA

#### ! IMPORTANT

20mm dual check valve supplied with machine must be installed on the cold water inlet to the machine. This valve is designed to prevent cross connection (back siphonage) and complies with **AS/NZS Standard 2845.1 (Watermark)**

- Fit the non-return valve A to the cold water inlet connection of the machine considering the flow direction marked on the valve.
- Fit the coupling B downstream the valve.
- Fit the water inlet hoses downstream the valve.

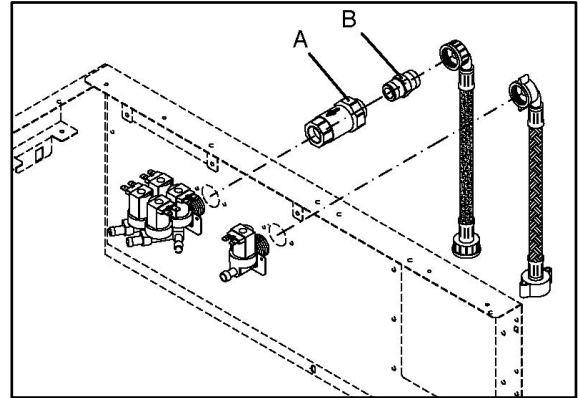

Fig. 3.6

### 3.3. Electrical connection

#### 3.3.1. Previous requirements



**CHECK THAT THE POWER AND FREQUENCY OF THE ELECTRICAL SUPPLY CORRESPONDS TO THOSE OF THE WASHER. Check the nameplate posted on the back panel of the machine.**



**ALL CONNECTIONS FOR ELECTRICAL SUPPLY MUST BE CARRIED OUT BY AUTHORISED INSTALLATION CONTRACTORS AND MUST COMPLY WITH THE STATUTORY SAFETY STANDARDS APPLICABLE TO EACH COUNTRY.**



**ALL THE MATERIALS USED IN THE ELECTRICAL INSTALLATION MUST COMPLY WITH THE STATUTORY SAFETY STANDARDS APPLICABLE TO EACH COUNTRY.**



**ALWAYS CONNECT THE GROUND EXTERNAL PROTECTION CIRCUIT. THIS UNIT MUST BE CONNECTED TO THE GROUND INSTALLATION WITH A CONDUCTOR CONNECTED TO THE EQUIPMENT GROUNDING TERMINAL.**



**HS-6013, HS-6017, EH030 AND EH040 GIRBAU WASHING MACHINES ARE DESIGNED TO OPERATE IN SINGLE-PHASE AND THREE-PHASE LINES. MODELS OF VOLTAGE BETWEEN 380 AND 415 V REQUIRE IN ADDITION A CONNECTION TO THE NEUTRAL WIRE.**

**IN INSTALLATIONS WITH SEVERAL SINGLE-PHASE MACHINES CONNECTED BETWEEN PHASE AND NEUTRAL IN THREE-PHASE LINES, IT IS RECOMMENDED TO DISTRIBUTE THE CONNECTION BY USING THE THREE PHASES TO BALANCE THE CONSUMPTION OF ALL THE PHASES IN THE LINE.**



**Specific warning for appliances installed IN THE USA /CANADA.**

#### **GROUNDING INSTRUCTIONS**

**This appliance must be connected to a grounded metal, permanent wiring system, or an equipment-grounding conductor must be run with the circuit conductors and connected to the equipment grounding terminal or lead on the appliance**

#### 3.3.2. Installation characteristics

Refer to specific characteristics on the ELECTRICAL CONNECTION table (section 1.5)

##### **Conductor:**

- The data referring to conductors are based on a multi-wire copper conductor.
- The length of the conductor from the safety switch to the washer must not be longer than 10 m.
- If using single-wire conductors, these must be encased within a safety conduit.
- The conductor must be affixed to the inlet opening of the machine using a secure connection appropriate for the type of conductor or safety conduit.
- The conductor must be secured against any pulling, crushing or rubbing.
- Additional specifications for the conductor: must comply with the statutory regulations of the country in which it is to be installed.

**Circuit breaker.** Install an earth-leakage protected circuit breaker.

Characteristics:

- installed in an easily accessible place.
- number of poles and intensity: consult ELECTRICAL CONNECTION table (section 1.5)
- A type
- protected against pulse currents, harmonics, the presence of continuous components, etc. (consult manufacturer specifications).

**Safety switch.** Install an Automatic on/off Switch, outside the washer, with individual protection for each machine.

Characteristics:

- number of poles and intensity: consult ELECTRICAL CONNECTION table (section 1.5)
- C type with top opening greater than 0.12 in (3 mm)
- must isolate electrical source phases and the N cable.
- mechanically lockable.
- installed in an easily accessible place.

**⚠ CAUTION !**  
**In machines with ETL mark, the SAFETY SWITCH must be UL489 approved.**

**3.3.3. Machine electrical connection**

- Disconnect and mechanically lock the external automatic switch.
- Open machine terminal box at the rear panel. Remove the support cover of the entry switch to the washer.
- On the entry hole of the electrical supply (**E** identified in figure 2) install a lock mechanism (not supplied with the washer) to fasten the cable or cable pipe protector, depending on the cable and pipe protector used. Refer to dimensions and connection diameter in INSTALLATION SPECS, section 1.4.
- Connect the wires directly to the switch breaker.
- The wire connection sequence to the main switch varies according to the machine connection and the power supply. This connection is indicated on the label posted next to the main switch.
- In models **HS-6024** and **EH060**, pass the conductor through the cable tie (**A**) and secure it as shown in Fig.3.7.

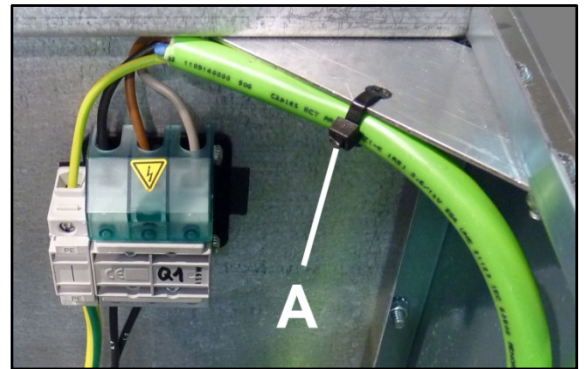

Fig. 3.7

**! FOR A CORRECT CONNECTION, FOLLOW THE INDICATIONS OF THE SECTIONS BELOW**

<b>LABEL</b>	PE/GND L1 L2/N	PE/GND L1 L2/N	PE/GND L1 L2 L3	PE/GND L1 L2 L3 N
<b>SUPPLY LINE</b>	⊕ L1 L2	⊕ L1 N	⊕ L1 L2 L3	⊕ L1 L2 L3 N
<b>HS/EH CONNECTION</b>	<b>PE/GND - L1 - L2</b> 	<b>PE/GND - L1 - N</b> 	<b>PE/GND-L1-L2-L3</b> 	<b>PE/GND-L1-L2-L3-N</b> 

**3.3.4. Transformer connection. Configuring the machine voltage**

**HS-6013/HS-6017 models**

- Disconnect and mechanically lock the external automatic switch.
- Remove the support cover (A) from the junction box located on the rear panel (Fig. 3.8).
- Connect the voltage selector (B) onto the transformer connector (C) in accordance with the power supply and with the accompanying table (Table 1).

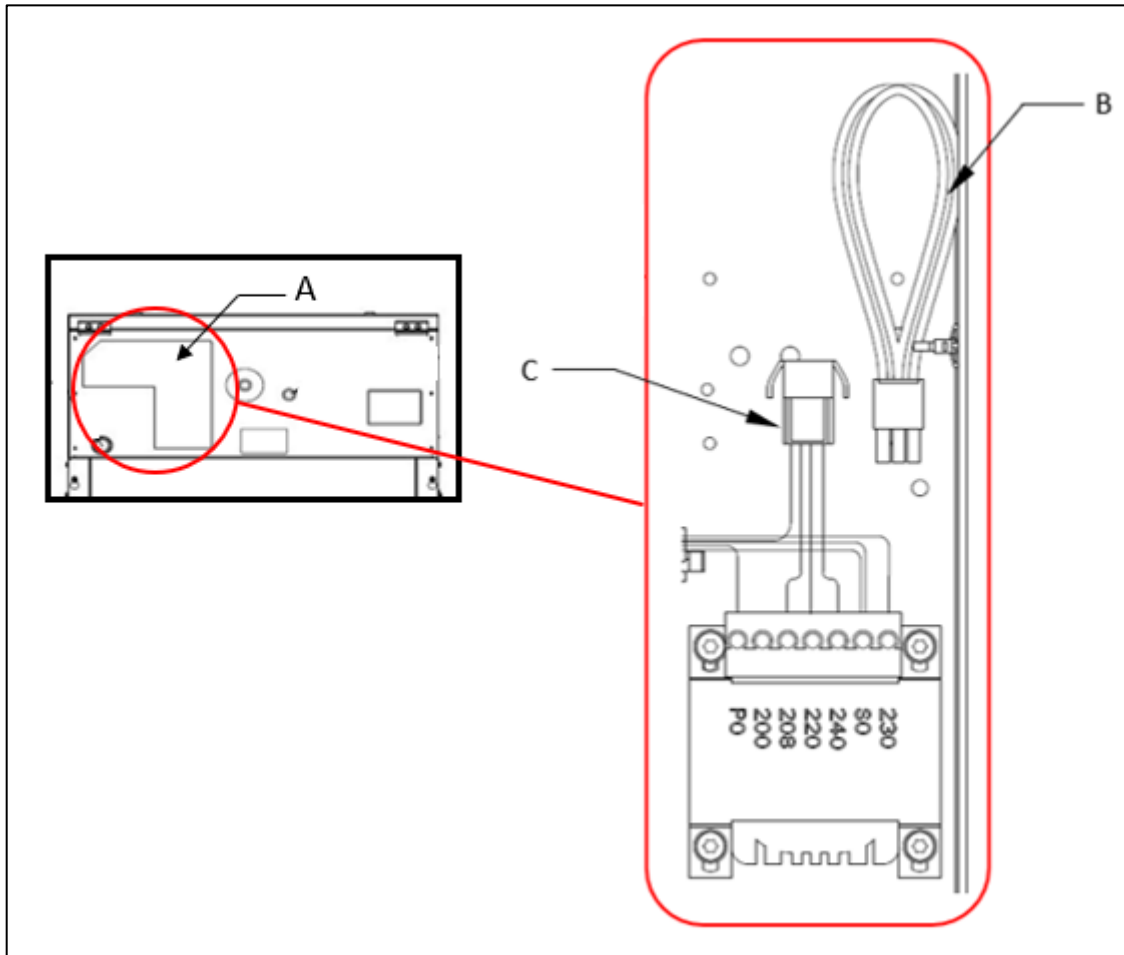

Fig. 3.8

**Table 1**

Mains voltage:	Selector B
<b>200V</b>	200V-208V
<b>208V</b>	200V-208V
<b>220V</b>	220V-230V-240V
<b>230V</b>	220V-230V-240V
<b>240V</b>	220V-230V-240V
<b>380V</b>	380V
<b>400V</b>	400V-415V
<b>415V</b>	400V-415V



**HS-6024/HS-6028/HS-6032 models**

- Disconnect and mechanically lock the external automatic switch.
- Open the machine's top cover.
- Connect the voltage selector switch (Fig. 3.10) in accordance with the mains power supply and the following table (Table 2).

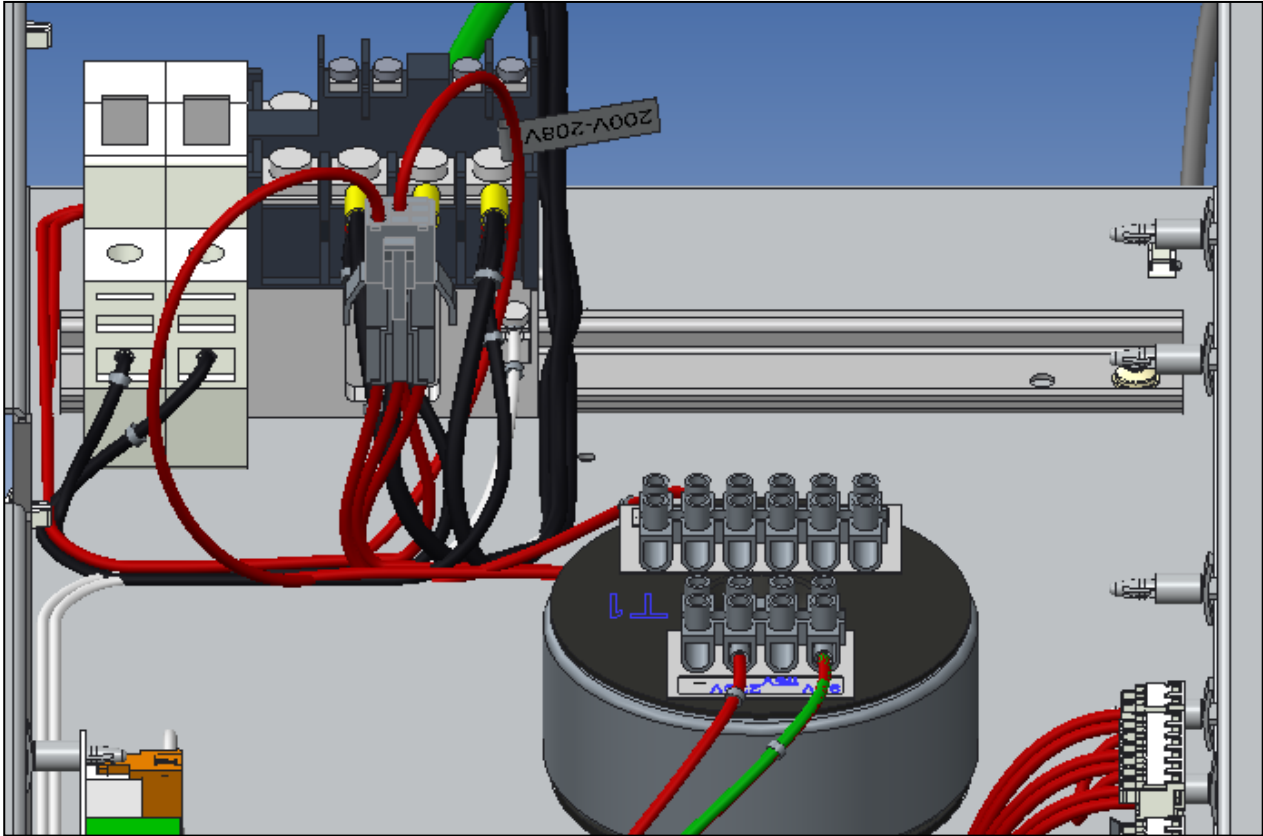

Fig. 3.9

**Table 2**

Mains voltage:	Voltage selector
<b>200V</b>	200V-208V
<b>208V</b>	200V-208V
<b>220V</b>	220V-230V-240V
<b>230V</b>	220V-230V-240V
<b>240V</b>	220V-230V-240V
<b>380V</b>	380V-400V
<b>400V</b>	380V-400V
<b>415V</b>	415V
<b>440V</b>	440V-480V
<b>480V</b>	440V-480V

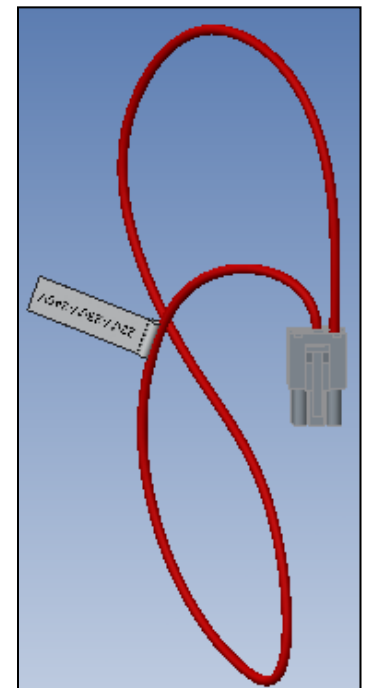

Fig. 3.10

### 3.4. Steam connection

In some models the body of the steam solenoid valve and the filter are shipped inside the drum of the washing machine, separate from the electrical wiring system. The coil is connected to the end of the electrical installation. In other models, the assembly solenoid valve and filter are supplied connected to the electrical wiring system.

#### Installation characteristics

Before connecting the installation to the solenoid valve, purge the pipe conduits.  
Place a mechanically lockable flow valve in the steam inlet in an accessible place.  
Check dimensions and connection diameters in the Installation specs (section 1.4).

#### Assembly and solenoid valve connection



**SEAL ALL THREADED UNIONS WITH A PRODUCT WHICH IS APPROPRIATE FOR STEAM PIPE CONDUITS.**

Respect the steam circulation direction indicated by an arrow on each part.

The coil has been previously removed from shipping position or disconnected from the solenoid valve (according to shipping braces)

The electrical wiring must be fastened to the cut out **VE** on the rear cover (see **Fig. 1.2** and section 1.4).

Place the solenoid valve on the end of the steam inlet pipe of the machine.

Machines in **USA/Canada**: place the small steam inlet hose (Fig. 3.11/A) to the filter inlet.

Connect the steam supply of the installation to the washer inlet.

Safeguard the installation against accidental contact. It is advisable to insulate the installation to prevent heat loss.

Place the coil on the solenoid valve body and fasten it with the core end screw.

Open the manual valve and check for leaks in the installation.

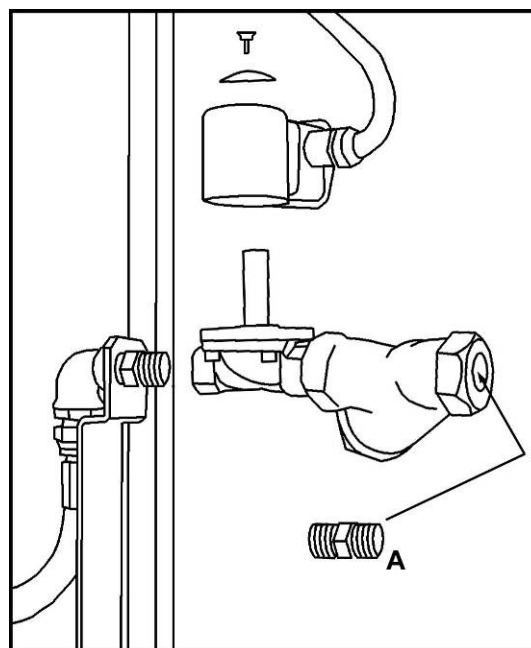

Fig. 3.11

### 3.5. External dosing (option)

The washer can communicate with external dosing equipment via electrical signals produced by the closure of relay contacts during wash cycle.

These relays are mounted on the board **A4**, located in the electrical supply input box, at the rear of the washer.

The relay contacts close the circuit between a COMMON input and the four outputs corresponding to each one of the dosing that the washer program runs.

The connection of the signal conductors is made on the various terminals of the terminal strip **X6** (board **A4**).

The icons on the label associated with the X6 terminal strip indicate the correspondence between each of the dosing and the terminals.

According to the characteristics of the external dosing equipment, two different connections can be used:

- dry contacts: see section 3.5.1.c.
- powered output signals, from the control washer circuit: see section 3.5.d. (power supply: 200...240V; 50/60Hz according to the washing machine).

Refer to the electrical connection specifications in the INSTALLATION SPECS, section 1.4.

**3.5.1. External dosing electrical connection**

**3.5.1.a. Steps prior to connection:**

- Disconnect and mechanically lock the external automatic switch.
- Open the machine's terminal box.
- On the entry hole of the external dosing electrical supply (**Ed** identified in figure 2) install a lock mechanism (not supplied with the washer) to fasten the cable or cable pipe protector, depending on the cable and pipe protector used. Refer to dimensions and connection diameter in **INSTALLATION SPECS**, section **1.4**.
- In models **HS-6024/HS-6028/HS-6032** and **EH060/EH070/EH080**, secure the conductor using the cable ties on the outside of the electrical cabinet, as shown in Fig. 3.12/A.

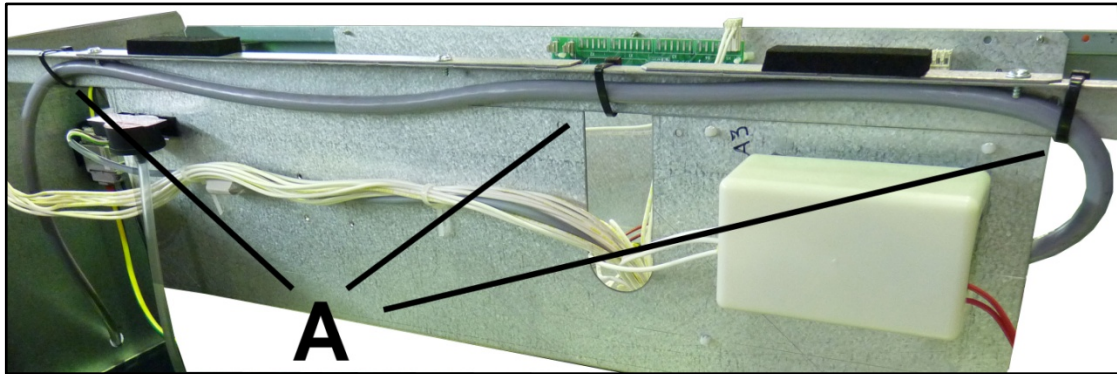

Fig. 3.12

**3.5.1.b. Signal conductor**

- Recommended section of signal wire: 0.75/1mm<sup>2</sup> (#16-18 AWG), 400V.
- If using single-wire conductors, these must be encased within a safety conduit.
- The conductor must be affixed to the inlet opening of the machine using a secure connection appropriate for the type of conductor.
- The conductor must be protected against traction, crushing and friction.
- Additional specifications for the conductor: must comply with the statutory regulations of the country in which it is to be installed.

**3.5.1.c. Dosing equipment connection**

**POTENTIAL FREE RELAY CONTACTS** (Fig. 3.13).

Origin of the dosing signals: from a source **EXTERNAL** to the washer (usually from the external dosing equipment).  
The relay contacts act as dry contacts (not powered).

**Dosing signals connection on X6 terminal strip**

- Follow the instructions on sections 3.5.1.a & b.
- Connect in the order indicated in the following chart.

X6	Logi / Coin control	Inteli control
∪ / 1	Pre-wash dosing	Dosing 1
≡ / 2	Wash dosing	Dosing 2
Δ / 3	Bleach dosing	Dosing 3
⊗ / 4	Softener dosing	Dosing 4
<b>COM</b>	Dosing equipment <b>COMMON</b> wire	



**The dosing signals ARE NOT PROTECTED by the washer fuses.**

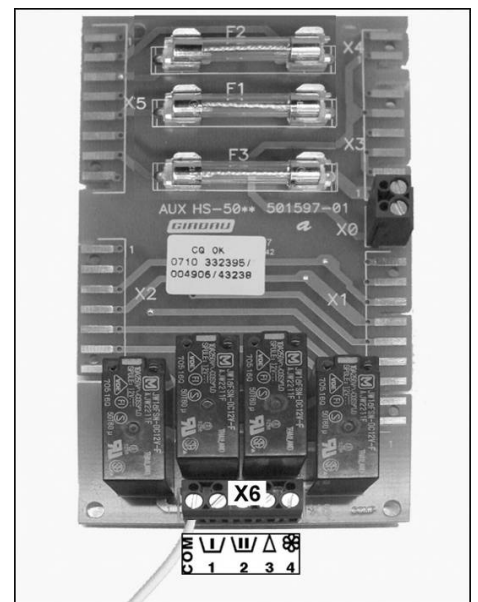

Fig. 3.13

**3.5.1.d. Dosing equipment connection. RELAY CONTACTS POWERED FROM THE WASHER CONTROL CIRCUIT. (Fig. 3.14)**

**⚠ IMPORTANT**





This connection allows for the maximum strength at each of the 50mA outputs. Higher consumption can prevent the washer from functioning correctly.

This connection can aggravate any problems produced by a fault in the grounding connection, both of the washer itself and of the external dosing equipment.

The external dosing control board incorporates a connection point (terminals identified as **X0**) allowing to generate dosing signals from the washer control circuit.

**Dosing signals connection (Fig. 3.14)**

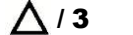
- Follow the instructions on sections 3.5.1.a & b.
- Supply **X6-COM** from terminal **X0-A** (wire not delivered).
- Supply the common phase of the signal outputs from **X0-B**.
- Dosing outputs: Connect in the order indicated in the following chart.

X6	Logi / Coin control	Inteli control
 / 1	Pre-wash dosing	Dosing 1
 / 2	Wash dosing	Dosing 2
 / 3	Bleach dosing	Dosing 3
 / 4	Softener dosing	Dosing 4

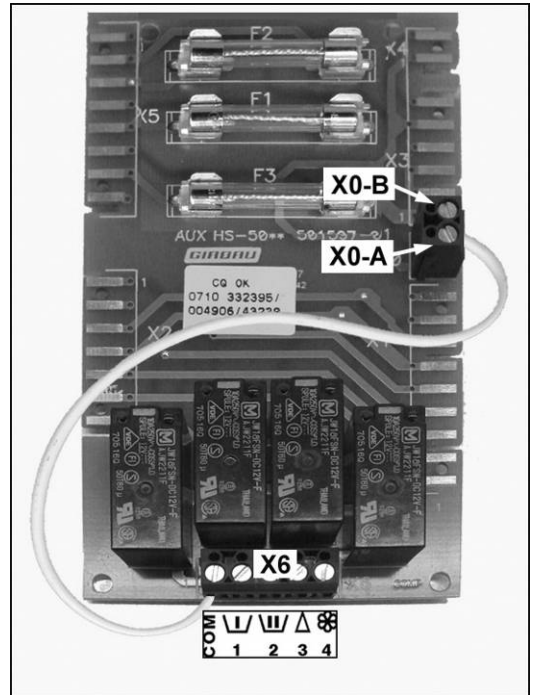

Fig. 3.14

**⚠ IMPORTANT**

Voltage between each dosing output signal X6 and X0-B, will be the same as electrical control circuit (200...240V; 50/60Hz according to the washer).

**INTELI CONTROL machines with optional auxiliary input and output board I/O2 (identified on the electrical diagram as A6).**

This option increases the number of external dosing signals by eight (in total, the washer will feature twelve external dosing signals).

The dosing signals of the auxiliary board are obtained via relay contacts **KA9...KA15**.

The connection of these eight signals is made using the connector **X3**. Common terminal: **X3-1** (Fig. 3.15).

See the washer's electrical diagram for more information.

The connection options are the same as those described in sections 3.5.1.c and 3.5.1.d.

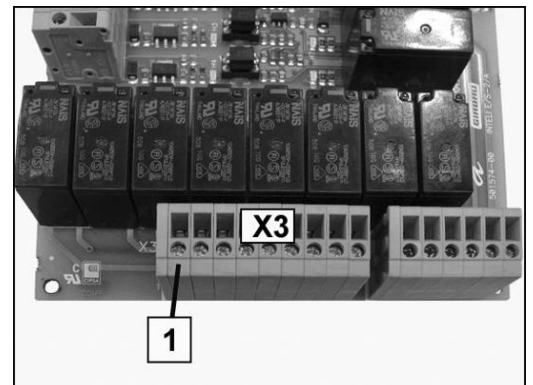

Fig. 3.15

### 3.5.2. External dosing hoses connection

The external dosing inlets are perforated and protected by a tube cap.

Refer to dimensions and dosing inlets diameter in INSTALLATION SPECS, section 1.4.

To connect the product cables:

- Locate the dosing inlets in the back of the machine.
- Remove the tube caps and save them.
- Connect the hoses to the nipples **A** on the manifold (Fig. 3.16).
- Fasten the dosing hoses to the washing machine with the appropriate clamps.

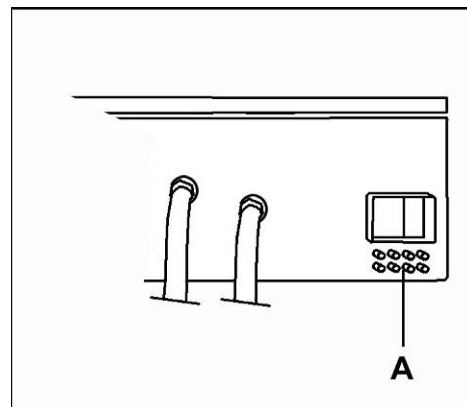

Fig. 3.16

### **!** CAUTION!

To avoid that non dissolved chemical products drip inside the washer, install the external dosing pumps (Fig. 3.17/A) and the chemical products conduction hoses (Fig. 3.17/B) below the dosing injection point (Fig. 3.17/C) to the washer. A simple bend of the conduction hoses below the level is not enough to avoid the dripping.

Omission of following this instruction can cause damage to the washer and void warranty.

### COIN CONTROL units:

To enable the external dosing system, you must modify the external dosing parameter at the MODIFICATION menu (see the Advanced Operation Instructions, for HS-6 / EH COIN CONTROL.

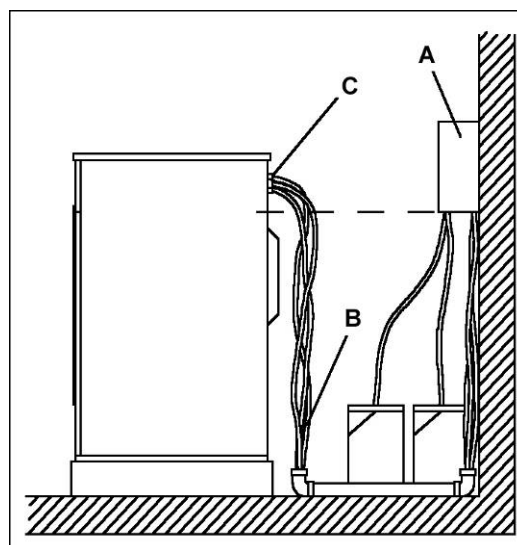

Fig. 3.17

### 3.5.3. Busy dosing unit signal

### **!** CAUTION!

**Option available in Inteli Control models only.**

To be able to use this option, the washing machine must be fitted with the A6 board, duly installed and activated in the SETUP menu.

Most dosing units that supply several washing machines simultaneously may issue a command to pause a washing program being run on one of the washers connected to this unit.

The aim of this pause is to send the washing chemicals at the right moment in each machine's washing cycle.

### Busy dosing unit signal connection

Refer to the washer electrical diagram to locate the connection points.

The busy dosing unit signal must be a signal between 5 and 35V.DC. in terminals X2.2(+) and X2.1(-) on the A6 board.

While such voltage is present, the microprocessor stops the program from continuing.

The duration of the signal will depend on the dosing unit.

See Inteli control Operation Manual for further information.

**3.6. External signal. Connection**



**Option available in Inteli Control models only.**

To be able to use this option, the washing machine must be fitted with the A6 board, duly installed and activated in the SETUP menu.

External signal. It is possible to use an order from the washing machine control to issue an end of program or alarm warning.

See Inteli control Operation Manual for further information.

**External signal specifications.**

Free voltage contact between terminals X4-5 and X4-6 on the A6 board.

Maximum intensity allowed: 1A.

Maximum voltage: 240V.AC.

**3.7. Tensioning belts**



**Excessive tightening will dramatically reduce the life of the motors and can cause breakage of the pulley or the shaft.**

**A belt that is too slack can lead to jerky movements and cause damage to the belt itself.**

To check the tension of the belts, apply a force in the centre of the span of 5 kg (11 lb) and tighten until obtaining the values shown in the table below.

	NEW BELTS	BELTS IN USE
HS-6013 EH030	10 mm (0.39 in)	12 mm (0.47 in)
HS-6017 EH040	7 mm (0.28 in)	9 mm (0.35 in)
HS-6023 EH055	18 mm (0.71 in)	20 mm (0.79 in)
HS-6024 EH060	9 mm (0.35 in)	10 mm (0.39 in)
HS-6028 EH070	9 mm (0.35 in)	11 mm (0.43 in)
HS-6032 EH080	9 mm (0.35 in)	11 mm (0.43 in)

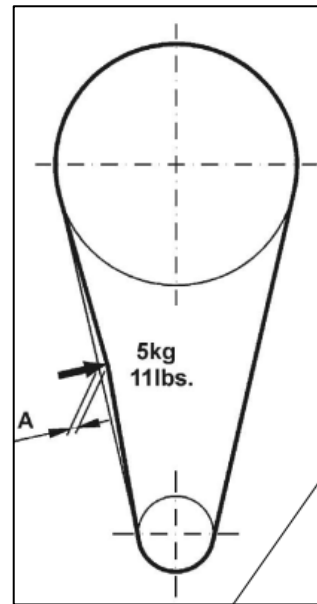

Fig. 3.18

### 3.8. Initial start-up



**THE WASHER MUST BE PUT INTO SERVICE BY AN AUTHORIZED TECHNICAL SERVICE.**

Before the initial START-UP, make sure that you accomplish the following points:

- Remove all packing materials. (Break them down in order to appropriately recycle them)
- Remove all tools used during the installation.
- Verify that all accessories have been removed from the drum interior.
- Verify the correct installation of all the accessories necessary for the washer operation.
- Check that the electrical installation corresponds with the voltage and the frequency of the machine.
- Verify that the four washer feet come in contact with the floor.
- Verify that all the shipping restraints are removed.
- Connect all the water, steam (steam heated washers) and power inlets according to the technical specifications.
- Open the manual water inlet valves (and steam if necessary) and check for any leaks around the manual flow valves and connection couplings.
- Connect the electricity supply.
- Check the operation (it is recommended to use the TEST program).
- Keep the manual in a safe place and in good condition for its possible consultation.
- Before washing clothes for the first time we recommend to run a complete cycle with detergent (1/4 the normal recommended amount).

### 3.9. Emergency stop in coin-op installations



**IN ACCORDANCE WITH SAFETY REQUIREMENTS FOR INDUSTRIAL MACHINERY STANDARD (UNE-EN ISO 10472-1,5-2) AND OTHER SAFETY REQUIREMENTS, THE LAUNDRY OWNER / USER IS RESPONSIBLE FOR INSTALLING A REMOTE LOCATED EMERGENCY STOP DEVICE, CONNECTED TO EACH MACHINE.**

#### Device conditions

To be located in a visible place, separated from all machines and easily accessible.

To break the electrical supply for all machines.

To safely isolate all machines at maximum consumption.

To require a RUN order for a new connection for the whole installation once the Emergency Stop button is unlocked.

### 3.10. Wash cycle start-up from an external device to the washing machine



**VERY IMPORTANT !!!**

**Washing machine cycle start-up should only be started by voluntary activation using an actuating element designated for this purpose.**

**For machines connected to a remote control start-up system (e.g. a central vending point, etc.), the control must be located so as to ensure that the operator may be absolutely certain that no person is exposed to any dangerous area of the washing machine (pursuant to Machine Directive 2006/42/CE, Annex 1)**

#### 3.10.1. Connecting to a central vending unit and configuring the machine

Consult the manual for INSTALLING AND CONFIGURING THE VENDING CIRCUIT part number 430731.